

SERIES AI25 Profibus

ACURO

Absolute Encoder

Key Features

- Up to 14 Bit of Singleturn and 12 Bits of True Multiturn Absolute Positioning
- Onboard Diagnostics
- Profibus Interface



SPECIFICATIONS

STANDARD OPERATING CHARACTERISTICS

Single-turn Resolution: 10, 12, 13, 14 Bit
Multi-turn Resolution: 12 bit
Linearity: +/- 1/2 LSB
Absolute Accuracy: ± 0.01° mechanical (36 arc-sec.)
Repeatability: ± 0.002° mechanical (7.2 arc-sec.)
Code format: Binary
 Electrical
Connection: Bus Cover with spring terminal clamps
Supply voltage: 10-30 VDC
Intrinsic current consumption: 200 mA (ST), 220 mA (MT)
Baud Rate: 12 Mbaud
Interface: Profibus-DP, Encoder Profile
Programmable: According to Class 2
Special Functions: Speed, Acceleration

MECHANICAL

Shaft diameter:
 Shaft: 6 mm (Servo Mount), 10 mm (Clamping Mount), 3/8" (Square Flange Mount)
 Hubshaft: 10mm, 12 mm, 3/8", 1/2"
Maximum shaft load:
 6 mm shaft: 13 lb axial, 24 lb radial
 10 mm shaft: 24 lb axial, 35 lb radial
Maximum shaft speed: 10,000 RPM (continuous), 12,000 RPM (peak)
Starting torque: < 1.4 in-oz
Weight (approx.): 350 g ST, 400 g MT
Shaft tolerance (hubshaft only): +/- 1.5 mm axial, +/- 0.2 mm radial
Flange configurations: Square, Clamp, Servo, Hubshaft with flexible tether
Bearing life:
 1 x 10¹⁰ revolutions at 35% full rated shaft load
 1 x 10⁹ revolutions at 75% full rated shaft load
 1 x 10⁸ revolutions at 100% full rated shaft load

ENVIRONMENTAL

Operating Temperature: -40 to 85° C
Storage Temperature: -40 to 100° C
Enclosure Rating: IP64 or IP67
Shock: 1,000 m/s² (6 ms)
Vibration: 100 m/s² (10 to 2,000 Hz)



Worldwide Brands: NorthStar™ • Acuro™ • Dynapar™ • Hengstler™ • Harowe™
 Headquarters: 1675 Delany Road • Gurnee, IL 60031-1282 • USA • Phone: 1.847.662.2666 • Fax: 1.847.662.6633

Satellite Locations:

- **North America:** North Carolina, South Carolina, Connecticut, Massachusetts, New York, Canada, British Virgin Islands
- **West Indies:** St. Kitts • **Europe:** United Kingdom, Italy, France, Germany, Spain, Slovakia
- **South America:** Brazil • **Asia:** China, Japan, Korea, Singapore

Customer Service:

Tel.: +1.800.873.8731
 Fax: +1.847.662.4150
custserv@dynapar.com

Technical Support

Tel.: +1.800.234.8731
 Fax: +1.847.782.5277
dynapar.techsupport@dynapar.com

European Sales Representative

Hengstler GmbH
 Uhlendstrasse 49, 78554 Aldingen
 Germany
www.hengstler.de

Ordering Information

To order, complete the model number with code numbers from the table below:

Code 1: Model	Code 2: Bits	Code 3: Mounting	Code 4: Shaft Size	Code 5: Protocol	Code 6: Electrical	Code 7: Connector
AI25	□□□□	□	□	□	□	□
AI25 Size25 Acuro Absolute Encoder	Single-Turn 0010 10 Bit 0012 12 Bit 0013 13 Bit 0014 14 Bit Multi-Turn 1212 12 Bit Multi-Turn, 12 Bit Single-Turn 1213 12 Bit Multi-Turn, 13 Bit Single-Turn 1214 12 Bit Multi-Turn, 14 Bit Single-Turn	Available when Code 4 is 0 or A 0 Servo* Available when Code 4 is 2 or C 1 Clamping* Available when Code 4 is 1 or B 2 Square flange** Available when Code 4 is 3, 4, 5 or 6 3 Hubshaft w/tether† † 58mm Dia. ** 2.5" Square † 63mm BC	w/o shaft seal (IP64) 0 6 mm 1 3/8" 2 10 mm 3 3/8" Hub Shaft 4 12 mm Hubshaft 5 1/2" Hubshaft 6 10 mm Hub Shaft w/ shaft seal (IP67) A 6 mm B 3/8" C 10 mm	6 Profibus	2 10-30 VDC	E Bus Cover 3 Strain Relief Exits. Internal T-coupler included G Bus Cover 2 Strain Relief Exits and 1 M12, 5-Pole Connector (for Tico display). Internal T-coupler included H Bus Cover Double Conin. Internal T-coupler included

DIMENSIONS

Code 3: Mounting

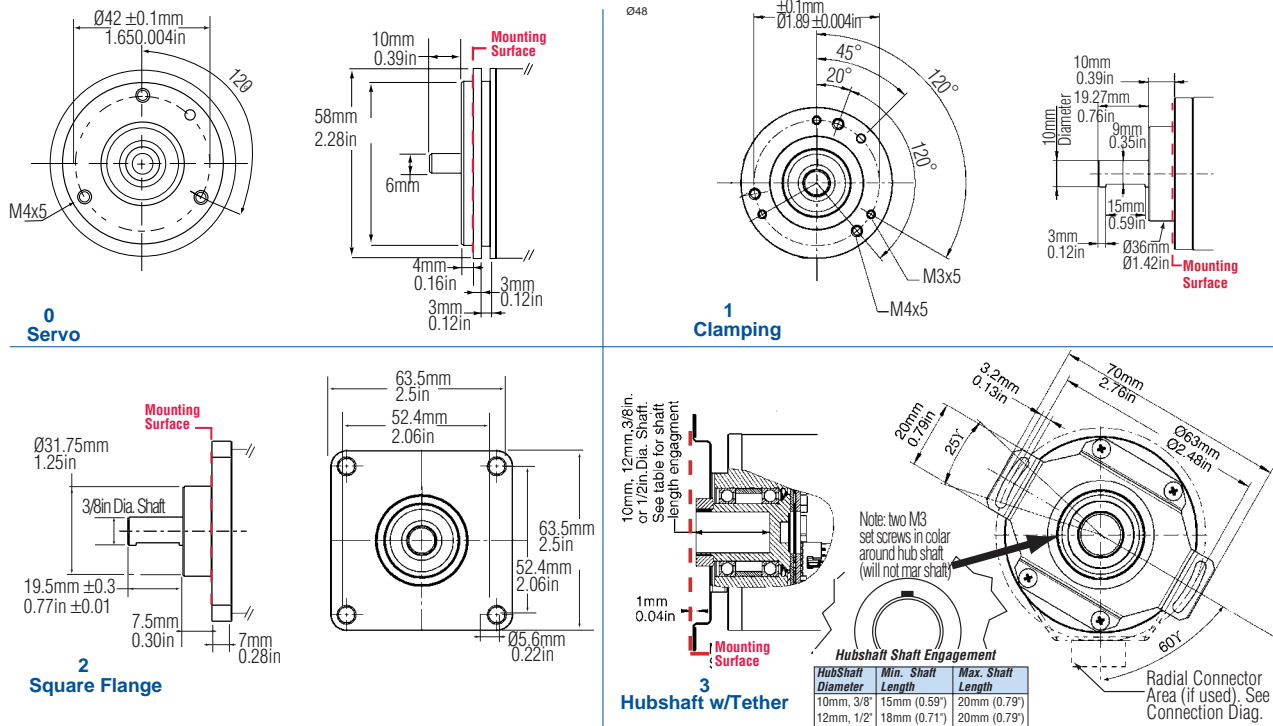

Code 7: Connector

