

Thyro-A



Thyristor-Leistungssteller
Thyro-A

Thyristor Power Controller
Thyro-A

Contents

1.	General	7
1.1	Type designations/Validity	7
1.2	Abbreviations	10
1.3	Special Features	10
1.4	Warranty	11
2.	Safety	12
2.1	Identification in the operating instructions	12
2.2	General danger information	13
2.3	Operator requirements	13
2.4	Personnel requirements	14
2.5	Intended use	14
2.6	Use of the device	15
2.6.1	Operation	15
2.6.2	Prior to installation/commissioning	15
2.6.3	Maintenance, service, faults	16
2.6.4	Transport	17
3.	Functions	18
3.1	Operating modes	18
3.1.1	Full wave switch principle TAKT	18
3.1.2	Phase angle principle VAR	19
3.1.3	Half wave switch principle QTM	19
3.2	Setpoint processing	19
3.3	Control modes	20
3.4	Limits	23
3.5	Pulse inhibition	23
3.6	Current and voltage transformer (only for ...H RL1 and ...H RLP1)	23
3.7	Display via analog output (only for ...H RL1 and ...H RLP1)	24
3.8	Error and status messages	24
3.8.1	LED messages	29
3.8.2	Fault signalling relay K1 (only for ...H RL1 and ...H RLP1)	31
3.9	Monitoring	32
3.9.1	Monitoring the mains voltage	32

3.9.2	Load monitoring (only for ...H RL1 and ...H RLP1)	33
3.9.3	Device temperature monitoring	33
3.9.4	Fan monitoring (for ...F...)	33
3.10	Extended functions (with bus module / THYRO-TOOL FAMILY)	33
3.10.1	Extended operating modes / circuit types	34
3.10.2	Averaging for the analog output	35
3.10.3	Control limits	35
3.10.4	Controller parameters	35
3.10.5	Mains load optimization	35
4.	Settings and operation	36
4.1	Device overview	37
4.2	DIP switches S1	39
4.2.1	Operating mode and load types	41
4.2.2	Control mode / Analog output	41
4.2.3	Live zero and setpoint input range	43
4.2.4	Analog output (only for ...H RL1 and ...H RLP1)	43
4.3	Potentiometer	44
4.3.1	Setting the transformer load (AN1, SST, T ₀)	45
4.3.2	Setting ohmic load	46
4.3.3	Setting maximum load value with control end U, U ² and P control	47
4.3.4	Setting maximum load current (only for ...H RL1 and ...H RLP1)	48
4.3.5	Setting example for maximum load value at control end / maximum load current	49
4.3.6	Adapting analog output (scale) (only for ...H RL1 and ...H RLP1)	50
4.3.7	Setting load monitoring (undercurrent monitoring) (only for ...H RL1 and ...H RLP1)	51
5.	Installation	58
5.1	Connecting terminals (Overview)	60
5.2	Connecting power supply	62
5.3	Connecting additional electronics supply (only for ...H RL1 and ...H RLP1)	62
5.4	Connecting pulse inhibition	63

5.5	Connecting analog setpoint input	63
5.6	Connecting control input for switch operation	63
5.7	Connecting the bus module	64
5.8	Using the analog output (only for ...H RL1 and ...H RLP1)	65
5.9	Using the THYRO-TOOL FAMILY	65
6.	Mains load optimization	68
6.1	Internal mains load optimization	68
6.2	Synchronization with Thyro-Power Manager	68
6.3	Software synchronization (operating mode TAKT)	69
7.	Connecting diagrams	71
8.	Help in the event of problems	79
9.	Technical data	82
10.	Dimension drawings	89
11.	Accessories and options	104
12.	Approvals and conformity	105

List of figures and tables

Fig. 1	Setpoint inputs and effective setpoint	19
Fig. 2	Operating elements	61
Fig. 3	User surface THYRO-TOOL FAMILY	67
Fig. 4	Connection diagram Thyro-A 1A...H1	71
Fig. 5	Connection diagram Thyro-A 2A...H1	72
Fig. 6	Connection diagram Thyro-A 1A ...H RL1, ... H RLP1	73
Fig. 7	Connection diagram Thyro-A 2A ...H RL1, ... H RLP1	74
Fig. 8	Connection diagram Thyro-A 3A...H1	75
Fig. 9	Connection diagram Thyro-A 3A ...H RL1, ... H RLP1	76
Fig. 10	Load connection types	77
Fig. 11	Additional electronics supply and connection with optional bus module	77
Fig. 12	Connection diagram mains load optimization with Thyro-Power Manager	78
Fig. 13	Connection diagram mains load optimization for operating mode TAKT	78
Tab. 1	Effects of a change in the load resistance	22
Tab. 2	Effective limits	23
Tab. 3	Limit values for mains voltage monitoring	32
Tab. 4	Maximum load value at control end	48
Tab. 5	Maximum load current	49
Tab. 6	Analog output (scale)	50
Tab. 7a	Load monitoring A 1A/2A, star delta, without neutral	52
Tab. 7b	Load monitoring Load with common star point and without neutral conductor	53
Tab. 7c	Load monitoring , A 2A, star point	54
Tab. 8	Load with common star point and without neutral conductor	55
Tab. 9	Load in delta connection	56
Tab. 10	Other possibilities of load monitoring	57
Tab. 11	Connecting terminals (Overview)	60

Contact

Technical queries

Do you have any technical queries regarding the subjects dealt with in these operating instructions?

If so, please get in touch with our team for power controllers:

Tel. +49(0)2902 763-520 or 763-290

Fax +49(0)2902 763-1201

Commercial queries

Do you have any commercial queries on power controllers?

If so, please get in touch with our team for power controllers.

Tel. +49 (0)2902 763-558 or (02902) 763-591

powercontroller@aegps.com

Service-Hotline

Our team is at your service on the following hotline:

AEG Power Solutions GmbH

Emil-Siepmann-Strasse 32

D-59581 Warstein

Tel. +49 (0)2902 763-558 or +49 (0)2902 763-100

<http://www.aegps.de>

Copyright

No part of these operating instructions may be transmitted, reproduced and/or copied by any electronic or mechanical means without the express prior written permission of AEG PS.

© Copyright AEG Power Solutions GmbH 2011.

All rights reserved

Further information on copyright

Thyro-A is an international registered trademark of AEG Power Solutions GmbH.

Windows and Windows NT are registered trademarks of the Microsoft Corporation.

All other company and product names are (registered) trademarks of the respective owners.

1. General

The Thyro-A is a communication-capable thyristor power controller. It can be used wherever alternating voltages, alternating currents or outputs in thermal process technology need to be controlled. The Thyro-A has several different control and regulation modes, can easily be connected to process and automation technology, has a high degree of control accuracy and is simple to handle.

These operating instructions describe the configuration and functions of the Thyro-A and are designed to enable qualified personnel to perform the following work:

- planning
- commissioning
- maintenance and repair

1.1 Type designations / Validity

These operating instructions describe the Thyro-A series versions ...H 1, H RL1 and ...H RLP1. Product characteristics that are only provided by the Thyro-A ...H RL1 and ...H RLP1 series are marked in the text.

These operating instructions comply with the current technical specifications of the device at the time of publication. The contents do not constitute a subject matter of the contract, but serve for information purposes only.

We reserve the right to alter any specifications given in these operating instructions, especially with regard to technical data, operation, weights and dimensions. AEG PS reserves the right to make modifications with regard to the content and technical data in these operating instructions.

Type code

The type designation of the thyristor-power controller is derived from the configuration of the power unit as well as from other features.

Thyro-A 1A	Thyristor controller with single phase power unit, suited for single phase loads
Thyro-A 2A	Thyristor controller with two phase power unit, suited for symmetrical loads in three phase operation in three phase saver circuit
Thyro-A 3A	Thyristor controller with three phase power unit, suited for three phase loads

Designation (example)	Characteristics	Different version of the power controller
Thyro-A 3A	Three phase power controller with three phase power unit	
...400-	with 400V type voltage	230V, 400V, 500V, 600V
...280	with 280A type current	16 ... 1500A
H	with integrated semiconductor fuse	*
F	with fan (from 280A types)	*
R	with signalling relay	*
L	with load monitoring	*
P	with additional power control (H RLP)	*
1	Identification Thyro-A, series	*

Example:

Thyro-A 3A...H1

* device-specific

Thyro-A ...H1

Thyristor power controller with integrated semiconductor fuse, system bus interface, TAKT and VAR operating modes, synchronization option (in TAKT operating mode with Thyro-Power Manager option) and control modes U, U^2 . Suitable for 3-phase operation in 3-phase circuit. Suitable for visualization and commissioning software from the Thyro-Tool Family.

Thyro-A ...HRL1

Thyristor power controller with integrated semiconductor fuse, system bus interface, additional 24 DC/AC electronic power supply, signalling relay, load monitoring and analog output, channel separation, with operating modes TAKT and VAR, synchronization option (in operating mode TAKT with Thyro-Power Manager), control modes U, U^2 , I, I^2 . Suitable for the visualization and commissioning software Thyro-Tool Family.

Thyro-A ...H RLP1

Thyristor power controller with integrated semiconductor fuse, system bus interface, additional 24 VDC/AC electronic power supply, signalling relay, load monitoring and analog output, channel separation, with TAKT and VAR operating modes, synchronization option (in operating mode TAKT with Thyro-Power Manager) and control modes U, U^2 , I, I^2 and P. Suitable for visualization and commissioning software Thyro-Tool Family.

1.2 Abbreviations

AEG PS	AEG Power Solutions GmbH
AN1	Phase angle of the 1st half-wave
SST	Soft start time
SYT	Synchro cycle
T_0	Cycle period
T_s	Switch-on time
Takt	Full wave switch principle - Thyrotakt
Var	Phase-angle principle - Thyrovar
QTM	Half wave switch principle - Quick takt mode

1.3 Special Features

- Integrated semiconductor fuse
- Type range 230-600V, 16-1500A, single phase, two phase and three phase
- Additional electronic supply, therefore also operation with mains voltages up to $0.43 \times U_{nom}$ possible (only ...HRL 1 and ...H RLP1)
- Ohmic load and transformer load, as well as load with high R_{warm}/R_{cold} (≤ 6) peak current limitation of $3 \times I_{nom}$ (only ...H RL1 and ...H RLP1) in operating mode VAR
- Soft start function for transformer load
- Channel separation, necessary with countervoltage
- Load current monitoring (only ...H RL1 and ...H RLP1)
- Signalling relay (only ...H RL1 and ...H RLP1)
- Analog output (only ...H RL1 and ...H RLP1)
- Control modes U, U^2 ; with ...H RL1 additional I, I^2 , with ...H RLP1 additional P
- Operating modes TAKT, VAR and QTM (with Thyro-A 1A)
- Synchronization option (for TAKT: with Thyro-Power Manager, for QTM: with internal mains load optimization)
- Triggering with analog setpoint via PC or optional bus adapter
- System interface standard
- Safe isolation in acc. with EN 50178 ch. 3
- UL approval (for standard devices 16-350A, 495-1500A in preparation)

- Connection for optional visualization and commissioning software Thyro-Tool Family (via PC-Interface RS232)

Options:

- Connection to various bus systems, e.g. Profibus DPV1, Modbus RTU) DeviceNet, CANopen, ProfiNet.
Other bus systems on request.
- PC-Interface and THYRO-TOOL FAMILY (visualization and commissioning software)

1.4 Warranty

In the event of any claims in connection with the Thyro-A, please contact us quoting:

- type designation
- fabrication number / Serial number
- reason for the complaint
- environmental conditions of the device
- operating mode
- period of use

Goods and services are subject to the general conditions of supply for products of the electrical industry, and our general sales conditions. Claims in connection with supplied goods must be submitted within one week of receipt, along with the delivery note. AEG PS will rescind all obligations such as warranty agreements, service contracts, etc. entered into by AEG PS or its representatives without prior notice if maintenance and repair work is carried out using anything other than original AEG PS spare parts or spare parts purchased from AEG PS.

2. Safety

2.1 Identification in the operating instructions

In these operating instructions, there are warnings before dangerous actions. These warnings are divided into the following danger categories:



DANGER

Dangers that can lead to serious injuries or fatal injuries.



WARNING

Dangers that can lead to serious injuries or considerable damage to property.



CAUTION

Dangers that can lead to injuries and damage to property.



CAUTION

Dangers that can lead to minor damage to property.

The warnings can also be supplemented with a special danger symbol (e.g. “Electric current“ or “Hot parts“), e.g.



risk of electric current or



risk of burns

In addition to the warnings, there is also a general note for useful information.



NOTE

Content of note

2.2 General danger information



DANGER

Electric current



Risk of injury from current carrying parts. There is a danger:

- in the case of devices not controlled, since the load circuit cannot be disconnected from the power supply network by the power controller.
- after disconnection from the power supply network, since the capacitors can still carry a dangerous residual voltage. Wait approx. 1 minute until the residual voltage has dissipated



DANGER

Electric current



Risk of injury from current carrying parts.

- Never operate the device without the cover



DANGER

Hot device



Risk of burns from heat sinks and neighbouring plastic parts

(> 70°C possible)

Do not touch the hot parts of the device.

Affix the “Risk of burns“ warning symbol in the immediate vicinity of the device.

2.3 Operator requirements

The operator must ensure the following:

- The safety regulations of the operating instructions are observed.
- The accident prevention regulations valid in the respective country of use and the general safety regulations are observed.
- All safety devices (covers, warning signs etc.) are present, in perfect condition and are used correctly.
- The national and regional safety regulations are observed.
- The personnel has access to the operating instructions and safety regulations at all times.

- The operating conditions and restrictions resulting from the technical data are observed.
- Should abnormal voltages, noises, increased temperatures, vibration or similar occur, the device is immediately put out of operation and the maintenance personnel is informed.

2.4 Personnel requirements

- Only qualified electro-technical personnel who are familiar with the pertinent safety and installation regulations may perform the following:
 - transport
 - installation
 - connection
 - commissioning
 - maintenance
 - testing
 - operation.
- These operating instructions must be read carefully by all persons working with or on the equipment prior to installation and initial start-up.

2.5 Intended use

The device may only be used for the purpose for which it was intended, as persons may otherwise be exposed to dangers (e. g. electric shock, burns) and plants also (e. g. overload). The user must therefore observe the following points:

- It is not permitted to make any unauthorised modifications to the unit or to use any spare parts or replacement parts not approved by AEG PS, or to use the unit for any other purpose.
- The warranty obligations of the manufacturer are only applicable if these operating instructions are observed and complied with.
- The device may only be used for control and regulation of electrical power.
- The device is a component that cannot function alone.
- Project planning must account for the proper use of the device.
- Never exceed the maximum permitted connection values as given on the type plate.

- The device may only be operated in conjunction with a connected ahead mains disconnect device (e. g. switch, VDE 0105 T1).
- It must be guaranteed that in the event of a fault, no uncontrolled currents, voltages or power may occur in the circuit.
- Despite proper use, it is possible in the event of a fault, that the device will not control the currents, voltages and power in the load circuit (example: if the power components are destroyed (broken down or high-resistance), the following reactions are possible: current interrupted, half wave operation, permanent flow of power).

2.6 Use of the device

2.6.1 Operation

- Only switch on the mains voltage at the device when there is no danger to persons, system or load.
- Protect the device against dust and damp.
- Ensure that the ventilation openings are not blocked

2.6.2 Prior to installation / commissioning

- If stored in a cold environment: ensure that the device is absolutely dry. (Allow the device a period of at least two hours to acclimatise before commissioning)
- Check that the voltage data on the type plate matches the mains voltage.
- Only install the device in an upright position.
- Ensure sufficient ventilation of the cabinet if mounted in a cabinet.
- Observe minimum spacing (clearance: 150 mm above, 100 mm below). The devices can be installed next to each other without spacing between.
- Ensure that the device cannot be heated up by heat sources below it. (The power loss is given in the type overview table, see page 87, Technical data).
- Ground the device in accordance with local regulations.
- Connect the device to the mains and the corresponding load in accordance with the connection diagrams.
- The device is parameterised when delivered. The parameters are adapted to the particular power unit. (Default: operating mode VAR without N-conductor). Check default settings and adjust to appli-

cation conditions if necessary (e.g. operating mode, control mode, limitations, monitoring, control characteristic curves, actual value output, fault messages etc.)



NOTE

Connecting the control signals

The following control signals are absolutely necessary for operating the devices:

- Setpoint (terminal X2.4 or via bus option)
- Pulse blocking (to ground, on terminal X2.1, X2.2; bridge present)
 - > Use shielded control conductors to connect the control signals.

If the pulse blocking bridge is not connected, the device is blocked and is not operating. Communication is still possible via the interface (see page 63, Connecting pulse blocking).

2.6.3 Maintenance, service, faults

In order to avoid personal and material damages, the user must observe the following:

- Before all work:
 - > Disconnect the device from all external voltage sources.
 - > Secure the device against accidentally being switched back on.
 - > Use suitable measuring instruments and check that there is no voltage present.
 - > Ground and short circuit the device.
 - > Provide protection by covers or barriers for any neighbouring live parts.
- The device may only be serviced and repaired by trained electro-technical personnel.
- There is a risk of damage when carrying out repair work on the power unit.

Various components of the power unit are screwed tight with a precise torque.

- > Repairs to power units have to be carried out by AEG Power Solutions GmbH!
- see also contact on page 6

2.6.4 Transport

- Only transport the device in the original packaging.
- Protect the device against damage, caused by jolts, knocks and contamination, for instance.

3. Functions

In order for the Thyro-A to be adapted as best possible to the required application, it has numerous functions. These functions are described in this chapter.



NOTE

Ideal adaption of the Thyro-A to the load

Choose the operating or control mode to adapt the Thyro-A to best match the load.



NOTE

Times given

The times given (duration), e. g. T_0 or SST are based on a 50 Hz mains frequency. With a mains frequency of 60 Hz, the times go down to 5/6 of the indicated value.

3.1 Operating modes

The user selects the operating mode most suitable for optimum adaptation to the various applications and manufacturing processes, as well as to different electrical loads.

3.1.1 Full wave switch principle TAKT

In this operating mode, the mains voltage is switched periodically, relative to the defined setpoint. Integer multiples of the mains periods are switched to avoid d.c. components. The operating mode full wave switch principle TAKT is particularly suited for loads with thermal inertia. The most important settings for this operating mode are the cycle time (T_0) and the transformer load (see page 45, Setting the transformer load).

The use of this function achieves the lowest mains feedback. Any mains feedback that will be still present (e.g. flicker) can be reduced to an insignificant amount using system load optimization (see page 35, Mains load optimization).

3.1.2 Phase angle principle VAR (only A 1A)

In this operating mode, the sinus wave of the mains voltage is shifted. The shift depends on the setpoint value. Characteristic of this operating mode are the high control dynamics.

When phase angle control VAR is used, harmonics of the mains voltage form. These can be compensated for with various types of circuit.

3.1.3 Half wave switch principle QTM (Quick Takt Mode only 1A)

QTM is the applied for a patent fast operating mode which works on the half wave switch principle. QTM is suitable for ohmic loads. Depending on the predetermined setpoint value, mains half waves are switched. DC components are avoided for the phase duration.

The fast phase control is particularly suited for IR beams as an alternative to phase-angle control. When using several controllers it is possible, by synchronization, to keep the mains feedback small.

3.2 Setpoint processing

Fig. 1: Setpoint inputs and effective setpoint

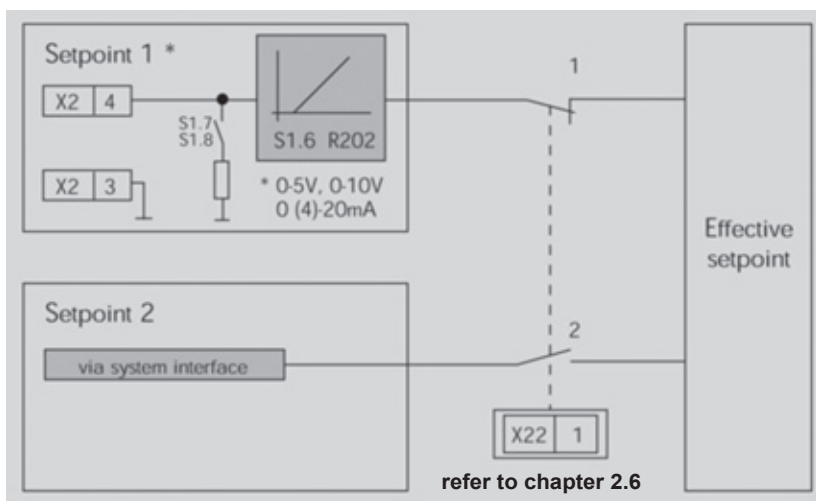

The user can adapt the setpoint signal to process controllers or to the automation system (see page 43, Live zero and setpoint input range).

This is done by altering the starting and finishing points of the control characteristic curve. All common signals can be used.

As soon as the power controller reaches a limit value (U_{\max} , I_{\max} , P_{\max}), this is indicated by LEDs (see page 29, LED messages).

The power controller has two setpoint inputs that are electrically isolated from the mains and of which only one is ever active.

- setpoint 1: analog signal X2.4 (+); X2.3 (ground)
- setpoint 2: via system interface (bus module, THYRO-TOOL FAMILY...)

The effective setpoint is the value when connected through. The setpoint input to be used is defined by configuring terminal X22.1 (see page 36, Settings and operation).

3.3 Control modes

The power controller has various different control modes.

Before commissioning the power controller and selecting a control mode, familiarization with the operating procedure and the effect upon the application is important.

Control modes ...H1	
Control mode	Control variable
U, U ²	highest conductor voltage

Control modes ...H RL1	
Control mode	Control variable
U, U ²	highest conductor voltage
I, I ²	highest phase current

Control modes ...H RLP1	
Control mode	Control variable
U, U ²	highest conductor voltage
I, I ²	highest phase current
P	total effective power

Fluctuations in mains voltage and changes in load are compensated directly by bypassing the inert temperature control circuit. This method is therefore particularly fast (secondary control).

Control characteristic curve and control variable

The control variable influencing the load is proportional to the effective setpoint in the case of control modes U, I, P. In control modes U^2 , I^2 , the control variable influencing the load is a square of the effective setpoint.

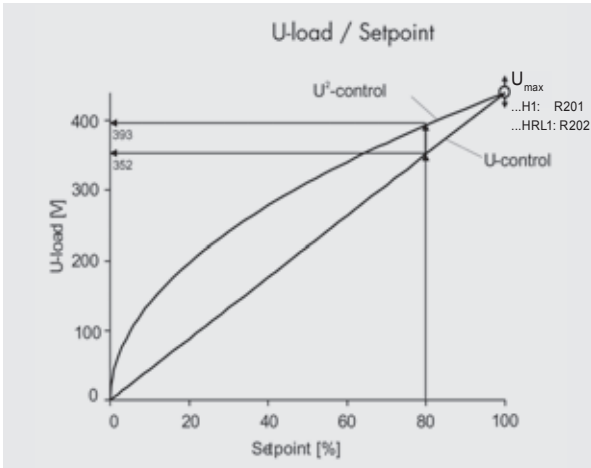

U Output voltage, U_{eff}

U^2 Output voltage, U_{eff}^2

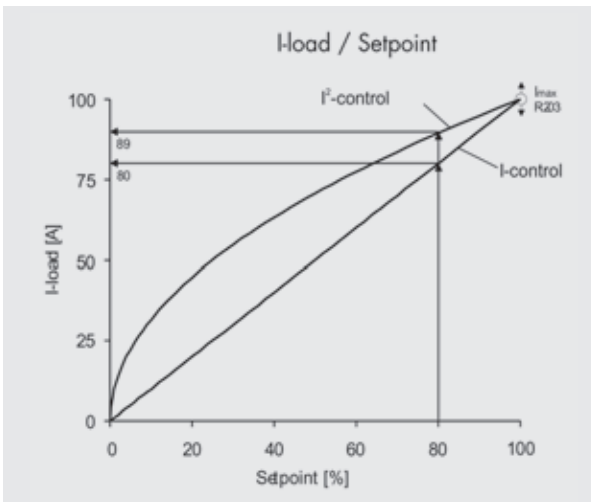

I Output current, I_{eff}

I^2 Output current, I_{eff}^2 (only with ...H RL1 and H RLP1)

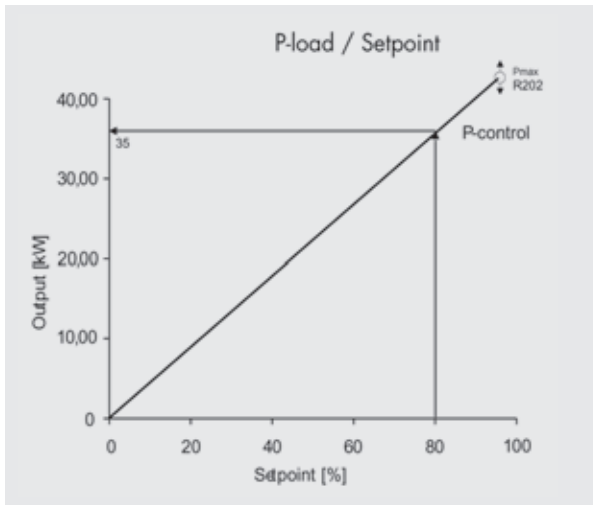

P Output power (only for ...H RLP1)

If the load resistance changes, e.g. due to temperature, ageing or load interrupt, the variables influencing the load change.

Tab. 1 Effects of a change in the load resistance

Control mode	Load resistance becomes smaller			Load resistance becomes greater		
	P	U_{Load}	I_{Load}	P	U_{Load}	I_{Load}
U	greater	=	greater	smaller	=	smaller
U^2	greater	=	greater	smaller	=	smaller
I^{*1}	smaller	smaller	=	greater	greater	=
I^{2*1}	smaller	smaller	=	greater	greater	=
P^{*2}	=	smaller	greater	=	greater	smaller

(*¹ for ...H RL1 and ...H RLP1, *² only for ...H RLP1)

3.4 Limits

In addition to setting the control mode, it is also possible to set limits for the following variables:

- Voltage limitation (U)
- Current limitation (I) (only for ...H RL1 and ...H RLP1)
- Power limitation (P) (only for ...H RLP1)

Tab. 2 Effective limits

Secondary control	Final value of the controller	Limits
U	$U_{\text{eff max}}$	$I_{\text{eff max}}^1$ P_{max}^1
U^2	$U_{\text{eff max}}$	$I_{\text{eff max}}^1$ P_{max}^1
I^{*1}	$I_{\text{eff max}}$	$U_{\text{eff max}}^1$ P_{max}^1
I^{2*1}	$I_{\text{eff max}}$	$U_{\text{eff max}}^1$ P_{max}^1
P^{*2}	P_{max}	$I_{\text{eff max}}^1$ $U_{\text{eff max}}^1$

(*1 for ...H RL1 and H RLP1, *2 only for ...H RLP1)

The Thyro-A 1A/3A ... H RL1 and ...H RLP1 also has peak current limiting ($I=3 \times I_{\text{nom}}$) at the phase angle.

3.5 Pulse inhibition

The pulse inhibition (PULSE INHIBIT; terminals X2.1 - X2.2 1.5 mm², grid 3.5) is activated by opening the pulse inhibition bridge, i.e. the power unit is no longer triggered. If the pulse inhibition is activated, the LED "PULSE INHIBIT" lights up red. After switching on or after pulse inhibition the first Takt-pulse (in Takt operation) takes place with the Soft-Start function. This is important for the transformer load if it was previously switched off for an undefined reason (remanence). For Thyro-A 2A or Thyro 3A the pulse inhibition is only wired to the master (L1, left).

3.6 Current and voltage transformer

(only for ...H RL1 and ...H RLP1)

For each power unit the power controller has a current transformer that is wired. The load voltage is obtained from the measuring signal of the mains voltage.

3.7 Display via analog output

(only for ...H RL1 and ...H RLP1)

The following variables are output at the analog output (e.g. when an external measuring instrument is connected):

Load current (highest phase current from L1, L2, L3)

Load voltage (highest conductor voltage)

Effective power (total power) (only with ...H RLP1)

Additional variables (can be selected via PC/bus, e.g. mains voltage setpoint etc.)

The user must configure which variable is to be output at the analog output, (see page 41, Control mode / Analog output). The analog output can also be used as a setting aid for potentiometer settings (see page 44, Potentiometer).

3.8 Error and status messages

The Thyro-A has internal error and status messages. The THYRO-TOOL FAMILY can be used to configure the consequences. The user can define what the reactions are to be in the event of a particular message. Possible reactions that can be set are blocking the load current (pulse inhibition) and an output at fault signalling relay K1 (only for ...H RL1 and ...H RLP1). The working principle can also be set at fault signalling relay K1. Basic error messages that make operation of the device impossible always result in pulse inhibition being actuated or fault signalling relay K1.

Overview Thyro-A...H1

Error messages	Pulse inhibition	
	fixed	configurable
Frequency error	x	
SYNC error	x	
Device excess temperature		x
Flash values invalid	x	
Master / Slave error	x	
Failure in rotating field / phase	x	

Status messages	Pulse inhibition	
	fixed	configurable
Undervoltage in mains		x
Overvoltage in mains		x
Pulse inhibition	x	

Default settings

Error message	Pulse inhibition
Frequency error	x
SYNC error	x
Device excess temperature	
Flash values invalid	x
Master / Slave error	x
Failure in rotating field / phase	x

Status messages	Pulse inhibition
Undervoltage in mains	x
Overvoltage in mains	
Pulse inhibition	x

Overview Thyro-A...HRL1 and Thyro-A...H RLP1

Error messages	Pulse inhibition		Fault signalling relay K1	
	fixed	configu- rable	fixed	configu- rable
Frequency error	x		x	
SYNC error	x		x	
Device excess temperature		x	x	
Undercurrent in load circuit		x	x	
Flash values invalid	x		x	
Master / Slave error	x		x	
Failure in rotating field / phase	x		x	

Status messages	Pulse inhibition		Fault signalling relay K1	
	fixed	configu- rable	fixed	configu- rable
Undervoltage in mains		x	x	
Overvoltage in mains		x	x	
Pulse inhibition	x		x	
U limit		x	x	
I limit		x	x	
P limit		x	x	

Fault signaling relay K1

	No message	Message
Closed circuit principle	closed	open
Open circuit principle	open	closed

Please refer also to chapter LED messages (see page 29) and chapter Fault signalling relay K1 (see page 31).

Default settings

Error message	Pulse inhibition	Fault signalling relay K1
Frequency error	x	x
SYNC error	x	x
Device excess temperature		x
Undercurrent in load circuit		x
Flash values invalid	x	x
Master / Slave error	x	x
Failure in rotating field / phase	x	x

Default settings

Status messages	Pulse inhibition	Fault signalling relay K1
Undervoltage in mains	x	x
Overvoltage in mains		
Pulse inhibition	x	
U limit		
I limit		
P limit		

Default settings

Closed circuit principle	Fault signalling relay K1
--------------------------	---------------------------

Possible settings in THYRO-TOOL FAMILY

Configure LEDs and relays [X]

Output:

Static

For each message displayed in the right-hand listbox, the LED or relay is set.

Do not display	Display
<input type="checkbox"/> Undervoltage in mains	<input type="checkbox"/> SYNC error
<input type="checkbox"/> Pulse switch-off	<input type="checkbox"/> Unit excess temp.
<input type="checkbox"/> U-Limit	<input type="checkbox"/> Undercurrent in load circuit
<input type="checkbox"/> I-Limit	<input type="checkbox"/> Invalid flash values
<input type="checkbox"/> P-Limit	<input type="checkbox"/> Undervoltage in mains
	<input type="checkbox"/> Master/Slave error
	<input type="checkbox"/> Failure in rotating field / phase

< >

Output deleted by regulator suppressor Mode

Output deleted by ext. error acknowledgement Monolop time

Principle

Configure pulse switch-off on error [X]

For each message displayed in the right-hand listbox, a pulse switch-off is automatically generated when the corresponding error occurs.

No pulse switch-off	pulse switch-off
<input type="checkbox"/> Unit excess temp.	<input type="checkbox"/> Undervoltage in mains
<input type="checkbox"/> Undercurrent in load circuit	
<input type="checkbox"/> Overvoltage in mains	

< >

3.8.1 LED messages

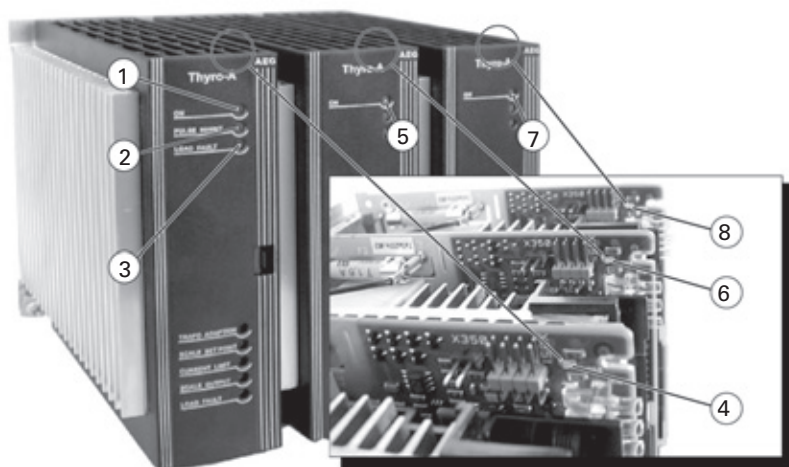

- 1 LED ON (green) Master
- 2 LED PULSE INHIBIT (red)
- 3 LED LOAD FAULT (red)
- 4 Internal LED (green) Master
- 5 LED ON (green) Slave1
- 6 Internal LED (green) Slave1
- 7 LED ON (green) Slave2
- 8 Internal LED (green) Slave2

LED messages

Message	LED ON (green)	LED PULSE INHIBIT (red)	LED LOAD FAULT (red)	Internal LED at Master (green)	Internal LED at Slave 1 (green)	Internal LED at Slave 2 (green)	Description
Device without voltage supply	OFF	OFF	OFF	OFF	-	-	Device not operating
Voltage supply present	ON	-	-	-	-	-	Voltage supply present
Control display	ON	OFF	-	Flash* ¹	Flash* ¹	Flash* ¹	Depending on the control, the internal LEDs flash at different speeds, from completely OFF to completely ON
Setting aid on analog output	ON	Flash fast	Flash fast	OFF	-	-	The analog output outputs a potentiometer value 30 seconds after the last potentiometer change: normal mode, alternating flashing
Frequency error	ON	Flash slow	OFF	OFF	-	-	Frequency outside 47Hz to 63 Hz
SYNC error	ON	Flash slow	OFF	OFF	-	-	Zero crossing of mains voltage faulty
Device excess temperature	ON	OFF	Flash slow	OFF	-	-	Excess temperature 90°/95°C internal/external
Undercurrent in load circuit	ON	OFF	ON	OFF	-	-	Undercurrent limit exceeded
Flash values invalid	ON	Flash* ¹ fast	Flash* ¹ fast	OFF	-	-	Parameters (in Flash) faulty or deleted
Undervoltage in mains	ON	ON	ON	ON	-	-	Mains voltage < than undervoltage limit (-57%)
Pulse inhibition	ON	ON	OFF	OFF	-	-	Bridge X2.1 - X2.2 open or set via bus
U limit I limit P limit	ON	Flash slow	Flash slow	OFF	-	-	U, I, or P limit reached, flash alternately
No communication with the slaves	ON	OFF	OFF	Flash slow	Flash fast	Flash fast	No communication with the slave
Error rotating field / phase	ON	Flash* ¹ slow	OFF	Flash* ¹ slow	Flash fast	Flash fast	Left rotating field or phase missing
OFF	LED not lights up		Flash slow	LED flashes slowly (1 Hz or 3.3Hz)			
ON	LED permanently lights up		Flash fast	LED flashes fast or flickers (14.7 Hz)			
-	Any other state of the LED		* ¹	LEDs flash simultaneously			

When the semiconductor fuse is triggered, this causes a voltage failure at the power controller. The device therefore switches off or announces a frequency error.

If the power controller is supplied from an external 24V source at the extra electronics supply input (see page 62, Connecting additional electronics supply), the device sends a frequency error message but does not switch off.

3.8.2 Fault signalling relay K1 (only for ...H RL1 and ...H RLP1)



NOTE

Default setting

The function explained here is described in the default state.

This setting can be changed with a bus module or with THYRO-TOOL FAMILY.

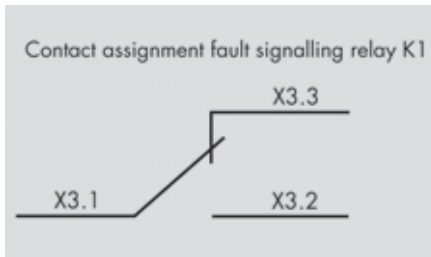

X3.1 root

X3.2 N/O contact

X3.3 N/C contact

Fault signalling relay K1 has a changeover contact. Messages that cause the fault signalling relay to switch can be set with THYRO-TOOL FAMILY. In the default state, fault signalling relay K1 functions on the closed circuit principle.

In the event of the following errors, the fault signalling relay de-energizes and the power controller switches off:

- SYNC error
- internal error
- undervoltage in the mains
- master/Slave error
- error rotating field / phase

In the event of the following errors, the fault signalling relay de-energizes, the power controller remains on and a message is sent (LED):

- excess temperature
- undercurrent in the load circuit

3.9 Monitoring

Power controller and load circuit are monitored for malfunctions. Messages are sent via LED (see page 29, LED messages), by bus or by fault signalling relay K1 (see page 31, Fault signalling relay K1).

3.9.1 Monitoring the mains voltage



NOTE

Limit values for voltage monitoring

The following limit values apply for voltage monitoring:

- Undervoltage monitoring: -57% of type voltage
- Overvoltage monitoring: +10% of type voltage

This results in absolute limit values for the monitoring of the mains voltage.

Tab. 3 Limit values for mains voltage monitoring

Type	Undervoltage limit	Overvoltage limit
230V	99V	253V
400V	172V	440V
500V	215V	550V
600V	258V	660V

Only for ...H RL1 and ...H RLP1

In the event of more than 15% below the type voltage, the devices can only be operated right up to the undervoltage limit if the electronics are supplied from an external 24V source.

For ...H1, ...H RL1 and ...H RLP1

In default state, pulse inhibition is switched internally when the undervoltage limit is exceeded, and fault signalling relay K1 de-energizes (both can be set with THYRO-TOOL FAMILY).

3.9.2 Load monitoring

(only for ...H RL1 and ...H RLP1)

The load can consist of one or more resistors connected in parallel or in parallel-series. It can be monitored up to a freely selectable absolute undercurrent limit value. The measured current is constantly compared with a settable undercurrent limit value. The device can thus detect an increase in load resistance. If the undercurrent limit value is exceeded, a message is sent. Where resistance elements are connected in parallel, a partial load interruption can be selected if the undercurrent limit value is set accordingly (see page 50, Setting load monitoring).

3.9.3 Device temperature monitoring



NOTE

Default setting

The function explained here is described in the default state. This setting can be changed with a bus module or with THYRO-TOOL FAMILY.

The Thyro-A has temperature monitoring. If the temperature is exceeded (90°), a message is sent via LED (see page 29, LED messages), via the bus module, or via fault signalling relay K1 (see page 31, Fault signalling relay K1). Pulse inhibition is not actuated.

3.9.4 Fan monitoring (for ...F...)

The forced ventilated thyristor power controllers have temperature monitoring for the heat sink. The temperature of the heat sink is measured. A temperature overrange of $>95^{\circ}$ triggers a signal and relay K1 is switched. The device, however, remains switched on (configurable default setting).

3.10 Extended functions

with bus module / THYRO-TOOL FAMILY)

Certain functions cannot be set via DIP switch or potentiometer. A bus module (e. g. Profibus DP, DeviceNet, Modbus RTU, CANopen) or a PC can be connected at the system interface X22.

This makes it possible to access further parameters, setpoints, actual values and error messages.

A few examples of extended functions are set out on the following pages.

3.10.1 Extended operating modes / circuit types

With the aid of THYRO-TOOL FAMILY, it is possible to set the operating mode and circuit type independently of one another. Combinations are thus possible which cannot be set with DIP switch S1.1 and S1.2.

Operating modes TAKT, VAR

Load circuits Star with neutral conductor, delta or star without neutral conductor, open delta

Possible settings in THYRO-TOOL FAMILY (operating mode)

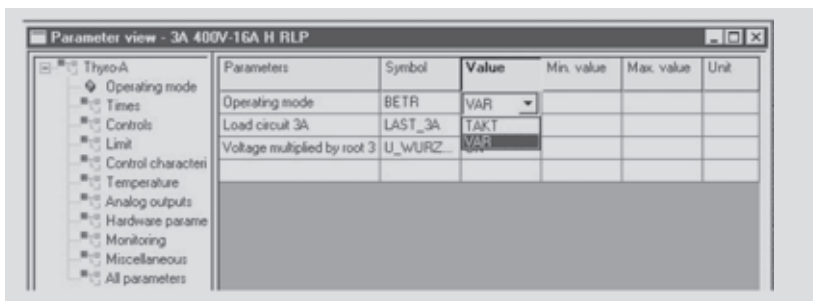

Possible settings in THYRO-TOOL FAMILY (circuit type)

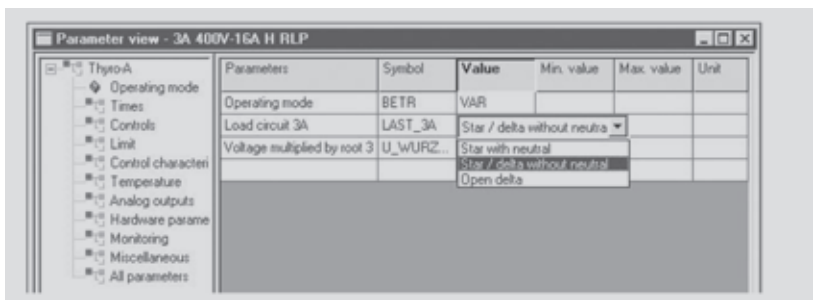

3.10.2 Averaging for the analog output

In order to attain a finer line thickness for line recorders, for example, the output signal can be smoothed if needed to suit the application.

MEAN 100	Mains periods (default setting)
----------	---------------------------------

3.10.3 Control limits

For operating modes TAKT and VAR, it is possible to set control limits (end position limits).

For Takt

T_{smax}	Maximum switch-on period
T_{smin}	Minimum switch-on period

For VAR

V_IE	Front pulse end position
H_IE	Rear pulse end position

3.10.4 Controller parameters

The parameters of the controller can be adapted to the path if needed.

Parameters

T_I	20	Controller I share
K_P	60	Controller P share
K_R	5	Controller amplification

* Default setting

3.10.5 Mains load optimization

The time for software synchronization can be set (see page 68, Mains load optimization).

(50Hz) => Delay period after mains returns $10\text{ms} * 100 = 1000 \text{ ms}$

(60Hz) => Delay period after mains returns $8.33\text{ms} * 100 = 833 \text{ ms}$

(Default setting: 100)

4. Settings and operation



DANGER

Dangers involved in settings and operation

Risk of injury / Risk of damage to the device or plant

- Observe all safety regulations in the chapter on safety.

Setting and operating the thyristor power controller is described in this chapter.

There are three ways of setting the power controller:

- on DIP switches and potentiometers (on device)
- via bus system (when operated in a bus system)
- via PC interface and THYRO-TOOL FAMILY

Certain settings can only be made on the device (DIP switch S1.7, S1.8 and S1.10), e.g. setting the analog input and output.

In the case of certain configurations / connection types, setting on the device itself is no longer possible:

- Operation with bus module (see also page 64, Connecting the bus module)
 - Ground to X22.1: Setpoint comes from bus. DIP switch and potentiometer are read in once after being switched on and the setting can then be changed with the bus module.
 - No ground to X22.1: DIP switch and potentiometer are always read in. Setpoint is read via the analog input.
- Operation with THYRO-TOOL FAMILY
 - Device in Thyro-Tool mode: DIP switch and potentiometer are ignored. Settings are read out of the memory and can only be changed via the PC.
 - Device not in Thyro-Tool mode: DIP switch and potentiometer are read in. Further settings can be changed via the PC. All parameters are visualized on the PC.



NOTE

Described settings

Settings made on the device itself are described in this chapter. Where reference is made to settings with a bus module or with the PC, this is indicated

4.1 Device overview



NOTE

Figures

Only one size of the Thyro-A is depicted in the operating instructions (16A/30A). The operation and display elements and terminals are arranged the same in all sizes (see page 89, Dimension drawings).

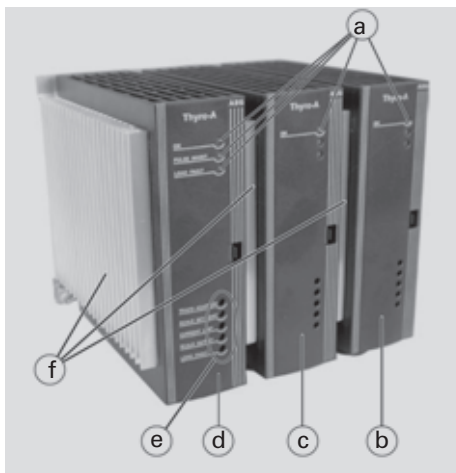

a	LEDs
b	Power section Slave2
c	Power section Slave1
d	Power section Master
e	Potentiometer
f	Heat sink

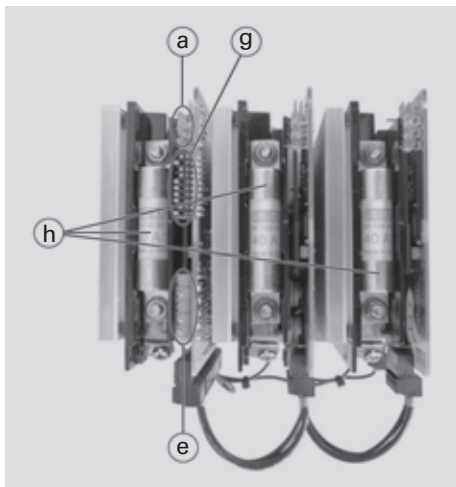

a	LEDs
g	DIP switch S1
e	Potentiometer
h	Fuse

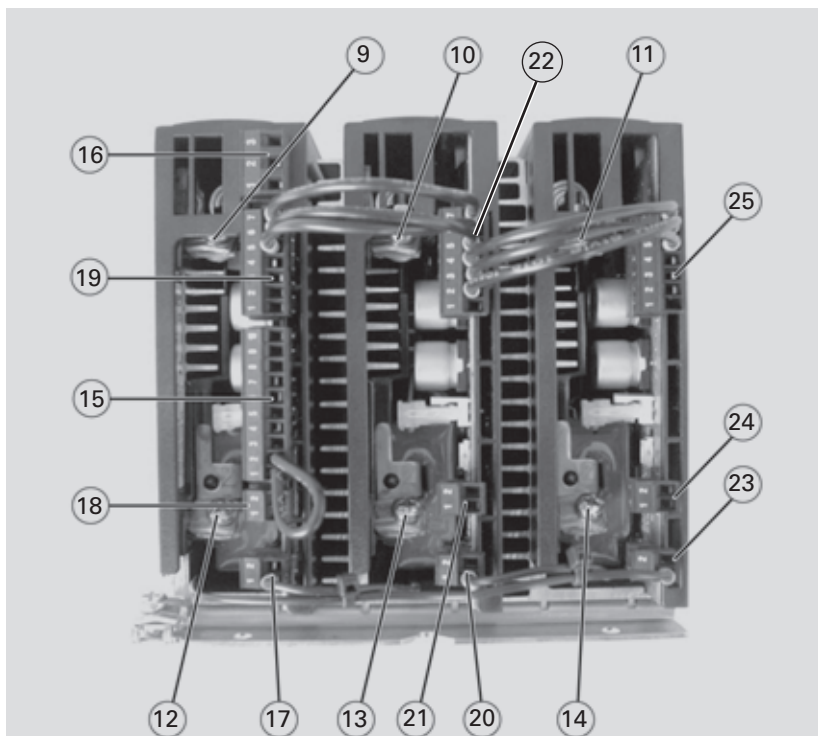

9	Connection terminal U1
10	Connection terminal V1
11	Connection terminal W1
12	Connection terminal U2
13	Connection terminal V2
14	Connection terminal W2
15	Terminal X2
16	Terminal X3
17	Terminal X1 Master
18	Terminal X11 Master
19	Terminal X22 Master
20	Terminal X1 Slave1
21	Terminal X11 Slave1
22	Terminal X22 Slave1
23	Terminal X1 Slave2
24	Terminal X11 Slave2
25	Terminal X22 Slave2

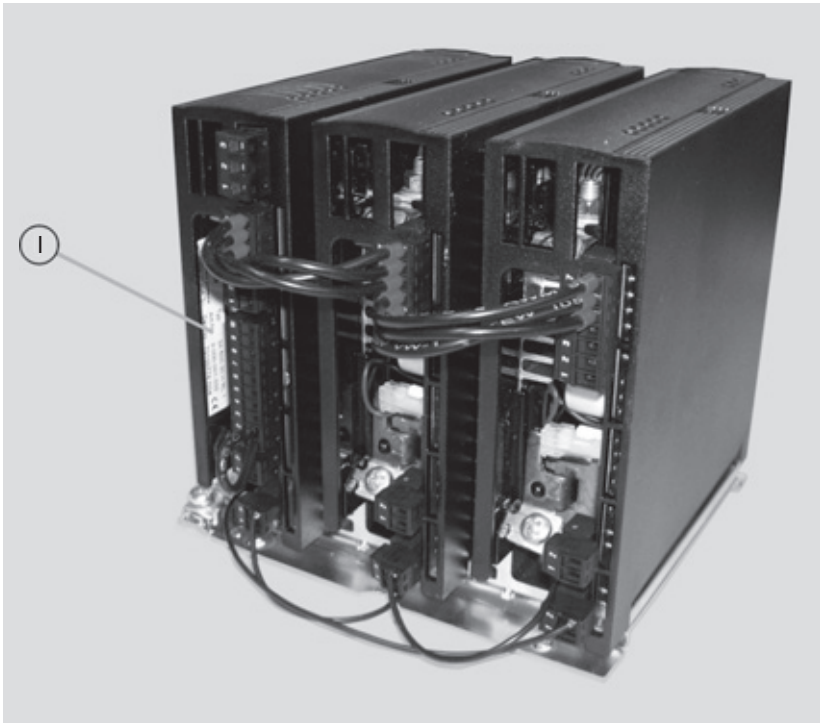

I Type plate

4.2 DIP switches S1

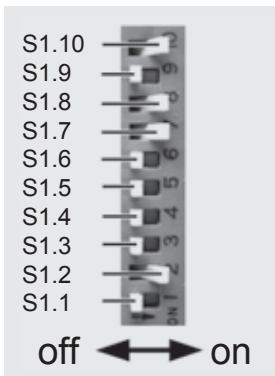

DIP switches S1 Thyro-A 1A... H1/HRL1 and Thyro-A 2A... H1/HRL1

Switch	Function	Default setting	
S1.10	Analog output 10V / 20mA*	ON	0-10V
S1.9	Live Zero analog output*	OFF	
S1.8	Setpoint input	ON	0-20mA
S1.7		ON	
S1.6	Live zero setpoint	OFF	0mA
S1.5	Control mode / Thyro-Tool mode	OFF	U ²
S1.4		OFF	
S1.3		OFF	
S1.2		OFF	
S1.1	Operating mode	ON	TAKT

* only for ...H RL1 and ...H RLP1

DIP switches S1 Thyro-A 1A... HRLP1 and Thyro-A 2A... HRLP1

Switch	Function	Default setting	
S1.10	Analog output 10V / 20mA*	ON	0-10V
S1.9	Live zero analog output*	OFF	
S1.8	Setpoint input	ON	0-20mA
S1.7		ON	
S1.6	Live zero setpoint	OFF	0mA
S1.5	Control mode/ Thyro-Tool mode	ON	P
S1.4		OFF	
S1.3		ON	
S1.2		OFF	
S1.1	Operating mode	ON	Takt

* only for ...H RL1 and ...H RLP1

DIP switches S1 Thyro-A 3A

Switch	Function	Default setting	
S1.10	Analog output 10V / 20mA*	ON	0-10V
S1.9	Live zero analog output*	OFF	
S1.8	Setpoint input	ON	0-20mA
S1.7		ON	
S1.6	Live Zero setpoint	OFF	0mA
S1.5	Control mode / Thyro-Tool mode	OFF	U ²
S1.4		OFF	
S1.3		OFF	
S1.2		ON	
S1.1	Operating mode	OFF	VAR

* only for ...H RL1 and ...H RLP1

For device configuration, there is a 10-pin DIP switch behind the cover of the master power unit. The DIP switch is only read in once by the control device at switch-on or when the mains returns. Before commissioning, the DIP switch must be set to suit the application.

- Switch off mains supply and secure against accidentally being switched back on.
- Remove the cover of the master power unit.
- Set configuration on the DIP switch.

The settings that can be made with the individual switches are described in the following chapters.

4.2.1 Operating mode and load types

Thyro-A 1A and Thyro-A 2A

S1.1	S1.2	Operating mode
OFF	OFF	None
ON	OFF	TAKT - Full wave switch principle
OFF	ON	VAR - Phase-angle principle
ON	ON	QTM - Half wave switch principle (Quick takt mode)

Thyro-A 3A

S1.1	S1.2	Load type and load connection
OFF	OFF	VAR, with open delta
ON	OFF	TAKT, with delta or star without neutral conductor
OFF*	ON*	VAR, with delta or star without neutral conductor
ON	ON	VAR, with star with neutral conductor
Can be set with		TAKT, with delta or star with neutral conductor
THYRO-TOOL FAMILY		TAKT, with open delta

* Default setting

4.2.2 Control mode / Analog output

The highest value of the load voltage or load current is always used for control and display. The total power is used for power control. If a bus module or PC is connected, control mode and analog output can be set separately, e.g. U control with I display.

Control mode for ...H1

S1.3	S1.4	S1.5	Control mode	Function R201
OFF*	OFF*	OFF*	U^2	Transformer load (phase angle 1 st half wave)
OFF	OFF	ON	U^2	$U_{load\ max}$
ON	OFF	OFF	U	Transformer load
ON	OFF	ON	U	Control characteristic
ON	ON	ON	Configurable with THYRO-TOOL FAMILY	None, since in THYRO-TOOL mode

* Default setting

Control mode for ...H RL1

S1.3	S1.4	S1.5	Control mode	Analog output	Function R202
OFF*	OFF*	OFF*	U^2	U_{load}	$U_{load\ max}$
ON	OFF	OFF	U	U_{load}	$U_{load\ max}$
OFF	ON	OFF	I^2	I_{load}	$U_{load\ max}$
ON	ON	OFF	I	I_{load}	$U_{load\ max}$
OFF	OFF	ON	I	U_{load}	$U_{load\ max}$
ON	OFF	ON	U^2	I_{load}	$U_{load\ max}$
OFF	ON	ON	U	I_{load}	$U_{load\ max}$
ON	ON	ON	Configurable with THYRO-TOOL FAMILY	Configurable with THYRO-TOOL FAMILY	None, since in THYRO-TOOL-mode

* Default setting

Control mode for ...H RLP1

S1.3	S1.4	S1.5	Control mode	Analog output	Function R202
OFF*	OFF*	OFF*	U^2	U_{load}	$U_{load\ max}$
ON	OFF	OFF	U	U_{load}	$U_{load\ max}$
OFF	ON	OFF	I^2	I_{load}	$U_{load\ max}$
ON	ON	OFF	I	I_{load}	$U_{load\ max}$
OFF	OFF	ON	I	U_{load}	$U_{load\ max}$
ON	OFF	ON	P	P_{load}	$P_{load\ max}$
OFF	ON	ON	P	I_{load}	$P_{load\ max}$
ON	ON	ON	Configurable with THYRO-TOOL FAMILY	Configurable with THYRO-TOOL FAMILY	None, since in THYRO-TOOL-mode

* Default setting

4.2.3 Live zero and setpoint input range

S1.6	S1.7	S1.8	Signal level	Input resistance
OFF	OFF	OFF	0-10V	88k Ω
OFF	OFF	ON	0-5V	44k Ω (e.g. for setpoint potentiometer)
OFF*	ON*	ON*	0-20mA	250 Ω
ON	OFF	OFF	2-10V	88k Ω
ON	OFF	ON	1-5V	44k Ω (e.g. for setpoint potentiometer)
ON	ON	ON	4-20mA	250 Ω

* Default setting

The analog input can be adapted to the various process controllers with the setpoint and live zero switches. The following signal ranges can be set:

0(4)-20mA (R_i = approx. 250 Ω), 0-5V (R_i = approx. 44k Ω), 0-10V (R_i = approx. 88k Ω).

+5V supply voltage can be taken from terminal X2.8 for a setpoint potentiometer ($5k\Omega < R_{Poti} < 10k\Omega$)

4.2.4 Analog output (only with ...H RL1 and ...H RLP1)

The analog output allows the effective values U_{load} , I_{load} or P (H RLP) to be displayed. The output signal level can be set.

Analog output

S1.9	S1.10	Output level
OFF*	ON*	0 - 10V
ON	ON	2 - 10V
OFF	OFF	0 - 20mA
ON	OFF	4 - 20mA

* Default setting

4.3 Potentiometer



There are five potentiometers below the LEDs with approx. 18 turns for the setting range.

Function

- Turn potentiometer to the right. > Value is increased.
- Turn potentiometer to the left. > Value is decreased.

Pos.-Nr.	Potentiometer	Designation	Function	Default setting
26	R201	TRAFO ADAPTION	Phase angle 1st half wave for transformer load	Thyro-A 1A 60°el. Thyro-A 2A 90°el. Thyro-A 3A 90°el.
27	R202*	SCALE SETPOINT	Control end	U-Regelung: $U_{type} + 10\%$ P-Regelung: $P_{type} + 10\%$
28	R203*	CURRENT LIMIT	Current limit	I_{type}
29	R204*	SCALE OUTPUT	Amplification	U_{type} , I_{type} , U_{type} , P depending on output variable of analog output
30	R205*	LOAD FAULT	Load monitoring	OFF (left stop pos.)

* only with ...H RL1 and H RLP1

Setting aid for ...H RL1 and ...H RLP1

There is a setting aid for the potentiometers.

- Connect the measuring device to the analog output (X2.9 (+) to X2.5 ground).
- > If a potentiometer is altered, the set value of the potentiometer is output at the analog output and not the actual value.
- > If the device is operated on mains voltage, the red LEDs flicker for the duration.
- > If the potentiometer is not greatly altered for 30 secs., the device automatically switches back to output of the selected actual value.

Since the analog output is designed for 0 - 20mA / 10V, 10mA (or 5V) correspond to 100%. This means that the set values can be read off directly or in percentages of the nominal value.

Analog output setting aid

20,0 mA or 10V	200%
10,0 mA or 5V	100% or 100°el.
5,0 mA or 2,5V	50% or 50°el
2,5 mA or 1,25V	25% etc.

Setting aid for ...H1, ...H RL1 and ...H RLP1

There are two setting options:

- Count the no. of turns of the potentiometer. The potentiometers have a setting range of 18 turns. (The setting range is not guaranteed and may deviate. If accurate settings are required, the potentiometer must be checked using a different method.)
- Visualize the setting with PC and THYRO-TOOL FAMILY.

4.3.1 Setting the transformer load (AN1, SST, T₀)

The settings described are relevant in operating mode TAKT.

- Set transformer load and SST on potentiometer R201 TRAF0 AD-APTION (Default setting: 60° el. with Thyro-A 1A as well as 90° el. with Thyro-A 2A and -A3A).

If wound core and toroidal core transformers are used, an optimization of this setting can be required.

With Thyro-A 1A generally 80°el turn (to the right), with Thyro-A 2A and Thyro-A 3A turn at smaller angles (to the left). An optimal setting is achieved when the rush current is minimal.

In order to minimise the rush current for transformers, it is possible to alter the angle of the first half wave on potentiometer R201 TRAFO ADAPTION.

Only for ...H1

Before adapting the transformer load:

- Switch DIP switch S1.5 to OFF

4.3.2 Setting ohmic load

- Recommendation: Set potentiometer R201 TRAFO ADAPTION to left stop.
 - > $T_0 = 100\text{ms}$
 - > Faster TAKT period is set.
 - > No phase angle of first half wave is set.
 - > Soft start time (SST) set to „0“.

Soft start time SST

The SST is set at the same time. This also applies to operating mode VAR. The soft start time has the following values depending on AN1:

- * For a soft start time SST of 30 periods or 600ms, the power controller remains in the SST ramp until setting time (T_s) is greater than 600ms. The power controller then pulses without SST ramp, even if T_s is less than 600ms. As soon as the power controller reaches the

AN1[°el]	SST [per]	SST [ms/50Hz]	Turns
<60	0	0	9
<63.7	6	120	10
>63.7	7	140	10
>71.2	8	160	11
>78.8	9	180	12
>86.2	10	200	13
>91.5	11	220	13
>94.5	13	260	14
>97.4	15	300	14
>100.5	20	400	15
>103.5	30	600*	15

setpoint, the SST becomes smaller and the ramp is always crossed once fully.



NOTE

Setting AN1, SST and T_0 independently

When a bus module or Thyro-Tool Family are used, parameters AN1, SST and T_0 can be set independently of one another.

- Setting potentiometer TRAF0 ADAPTION R201 to left stop.
> At $<30^\circ\text{el}$ the device automatically switches to a faster Takt operation with $T_0 = 5$ periods without SST. Then terminal X2.7 can be used as control input for switch operation.



When using the synchronization options, via R201 must be set parameter AN1 $>30^\circ\text{el}$ ($T_0 = 1000\text{ms}$).

Analog output (setting aid)

10.0mA / 5V	100°el
6.0mA / 3,0V	60°el Thyro-A 1A (default)
9.0mA / 4,5V	90°el Thyro-A 2 & 3A (default)
3.0mA / 1,5V	30°el
2.5mA / 1,25V	0°el

4.3.3 Setting maximum load value with control end U, U² and P control

For ...H RL1 and ...H RLP1

With potentiometer R202 SCALE SETPOINT, the maximum voltage (for U, U² control) or the maximum power (for P control) is set on the load, depending on the control mode ^{*1}. If no P control is set, the potentiometer works as voltage limitation. The end value of the control characteristic is adapted accordingly (see following table).

Analog output: X2.9 (+); X2.5 (ground)

^{*1} only for ...H RLP

- Set maximum load value (of U or P) at control end on potentiometer R202 SCALE SETPOINT.

Tab. 4 Maximum load value at control end

4.a Thyro-A 1A ,-A2A

Setting	$U_{load\ max}$ Potentiometer R202 SCALE SETPOINT	$P_{load\ max}^1$ Potentiometer R202 SCALE SETPOINT
Potentiometer turns (from left stop)	$9 * U_{load\ max} / U_{type}$	$5.2 * P_{load\ max} / P_{type}$
Setting aid, analog output in mA (Switch S1.10 = „OFF“)	$10mA * U_{load\ max} / U_{type}$	$5.77mA * P_{load\ max} / P_{type}$
Setting aid, analog output in vols (Switch S1.10 = „ON“)	$5V * U_{load\ max} / U_{type}$	$2.89V * P_{load\ max} / P_{type}$

4.b Thyro-A 3A

Einstellung	$U_{load\ max}$ Potentiometer R202 SCALE SETPOINT	$P_{load\ max}$ Potentiometer R202 SCALE SETPOINT
Potentiometer turns (from left stop)	$9 * U_{load\ max} / U_{type}$	$7.8 * P_{load\ max} / P_{type}$
Setting aid, analog output in mA (Switch S1.10 = „OFF“)	$10mA * U_{load\ max} / U_{type}$	$8.66mA * P_{load\ max} / P_{type}$
Setting aid, analog output in volt (Switch S1.10 = „OFF“)	$5V * U_{load\ max} / U_{type}$	$4.33V * P_{load\ max} / P_{type}$

For ...H1

When DIP switch S1.5 is at „ON“, the maximum load voltage (with U/U^2 control) can be defined on potentiometer R201 TRAFO ADAPTION. The control characteristic curve is adapted in accordance with the following equation: $U_{load\ max} = (\text{No. of turns R201} : 9) * U_{type}$

4.3.4 Setting maximum load current (only for...H RL1 and ...H RLP1)

The maximum load current is limited with potentiometer R203 CURRENT LIMIT, irrespective of the control mode. If there is no I control, the potentiometer works as current limiter.

At reduced ambient temperatures, the power controller can only be operated with up to 110% of its nominal current (effective value) (see page 82, Technical Data).

Tab. 5 Maximum load current

Setting	$I_{load\ max.}$ Potentiometer R203 CURRENT LIMIT
Potentiometer turns (from left stop)	$9 * I_{load\ max} / I_{type}$
Setting aid, analog output in mA (Switch S1.10 = „OFF“)	$10mA * I_{load\ max} / I_{type}$
Setting aid, analog output in volts (Switch S1.10 = „ON“)	$5V * I_{load\ max} / I_{type}$

Analog output: X2.9 (+); X2.5 (ground)

When the limit is reached, the red LEDs flash alternately approx. once a second. (Same LED display with peak current limiting)

- Set maximum load current at potentiometer R203 CURRENT LIMIT

4.3.5 Setting example for maximum load value at control end / maximum load current

Example for maximum load value / maximum load current

Thyro-A 3A 400-30 H RLP1 ($U_{type} = 400V$, $I_{type} = 30A$, $P_{type} = 20.7kW$)
 - Power control with limit to 15kW
 - Current limit to 25A
 - Setpoint 4-20mA

P_{max}		Setting aid
1 st setting R202:	$7.8 * (15kW/20,7kW)$	5.65 turns (from left stop)
Setting aid in mA:	$8.66mA * (15kW/20,7kW)$	6.25mA
Setting aid in volts:	$4.33V * (15kW/20,7kW)$	3.13V
I_{max}		Setting aid
2 nd setting R203:	$9 * (25A/30A)$	7.5 turns (from left stop)
Setting aid in mA:	$10mA * (25A/30A)$	8.33mA
Setting aid in volts:	$5V * (25A/30A)$	4.16V

4.3.6 Adapting analog output (scale) (only for ...H RL1 and ...H RLP1)

The scale of the analog output is adapted with potentiometer R204 SCALE OUTPUT, if, for example, the scale of the display does not correspond to the nominal data (see page 41, Analog output).

Tab. 6a Analog output (scale) Thyro-A 1A, 2A

Setting (default = 0-20mA, corresponds to type value (current/voltage/power)	1A (H, HRL1, HRLP1) at U-, I-, P display - 2A (H, HRL1, HRLP1) at U-, I-display Potentiometer R204 SCALE OUTPUT	2A (HRLP1) at P display Potentiometer R204 SCALE OUTPUT
Potentiometer turns (from left stop)	4 turns * (type value power controller / scale end value)	4.62 turns * ($P_{\text{type power controller}} /$ scale end value)
Setting aid, analog output in mA (Switch S1.10 = „OFF“)	4mA * (type value power controller / scale end value)	4.62mA * ($P_{\text{type power controller}} /$ scale end value)
Setting aid, analog output in mA (Switch S1.10 = „ON“)	2V * (type value power controller / scale end value)	2.13V * ($P_{\text{type power controller}} /$ scale end value)

Tab. 6b Analog output (scale) Thyro-A 3 A

Setting (default = 0-20mA, corresponds to type value/ (current/voltage/power)	3A (H, HRL1) at U-, I display Potentiometer R204 SCALE OUTPUT	3A (HRLP1) at P display* ¹ Potentiometer R204 SCALE OUTPUT
Potentiometer turns (from left stop)	3.6 turns * (type value power controller/scale end value)	6.24 turns * ($P_{\text{type power controller}} /$ scale end value)
Setting aid, analog output in mA (Switch S1.10 = „OFF“)	4mA * (type value power controller/scale end value)	6.93mA * ($P_{\text{type power controller}} /$ scale end value)
Setting aid, analog output in volts (Switch S1.10 = „ON“)	2V * (type value power controller/scale end value)	3.46V * ($P_{\text{type power controller}} /$ scale end value)

Analog output: X2.9 (+); X2.5 (ground) *1 only with ...H RLP1

Example adaptation at the analog output

Thyro-A 3A 400-30 H RLP1 ($U_{\text{type}} = 400\text{V}$, $I_{\text{type}} = 30\text{A}$, $P_{\text{type}} = 20.7\text{kW}$)

Measuring instrument for 4-20 mA with scale 20 kW

		Setting aid
Setting R204:	6.24 * (20,7kW/20kW)	6.5 turns (from left stop)
Setting aid in mA:	6.93mA * (20,7kW/20kW)	7.17mA
Setting aid in V:	3.46V * (20,7kW/20kW)	3.58V

4.3.7 Setting load monitoring (undercurrent monitoring)

(only for ...H RL1 and ...H RLP1)

This function enables a freely selectable absolute current limit to be monitored. The value can be set using the R205 potentiometer or the Thyro-Tool Family. During the configuration process via potentiometer the monitoring value will be indicated at the analog output. This monitoring of absolute values is suitable for one or several load resistors set up in parallel. Basically the effective value of the current measured is continually compared with a configurable absolute current limit for undercurrent. If it drops below this limit message is sent. In the case of resistors set up in parallel, by setting the respective undercurrent limit can be selected a partial load break.

- Set load monitoring on the potentiometer R205 LOAD FAULT. The default setting of this monitoring is OFF (=left stop of the potentiometer R205).

A measuring instrument connected to the analog output can be used as setting aid (see page 44, Potentiometer). If the actual value is fallen below the set value, a message is sent (LED, by bus and fault signalling relay K1).



NOTE

Remarks on settings / tables

- Settings over 90% and fewer than 10% not make sense. If the load currents are considerably less than the nominal currents of the power controller, consider using a smaller power controller.
- In operating mode VAR, monitoring is blocked for large control angles (for load with neutral conductor $\alpha > 140^\circ \text{el.}$, for load without neutral conductor $\alpha > 117^\circ \text{el.}$)
- The signalling delays can be up to 15 secs. in operating mode VAR and up to 30 secs. in operating mode TAKT.
- Convert deviating values as a percentage. The set monitoring value should always be an average of the value for load nominal current and the value after failure.

Thyro-A 1A and Thyro-A 2A

Load with separate star point without neutral conductor

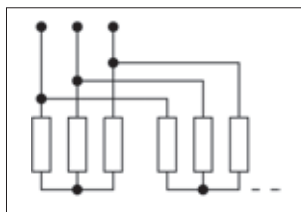

For Thyro-A 1A and Thyro-A 2A/3A (load with separate star point without N) a setting for load monitoring can be made according to the table below:

Tab. 7a Load monitoring

		Thyro-A 1A Thyro-A 2A Load with separate star point without N				
e.g. parallel load resistors	$I_{load\ nom}/I_{type\ controller}$	Resistance increase in case of fault	Recommended setting for Poti R205	X2.9 [V] [0-10V]	X2.9 [0-20mA]	ca. turns
number						
1	100%	infinite	50.0%	2.50	5.00	8.5
1	80%		40.0%	2.00	4.00	7.0
1	60%		30.0%	1.50	3.00	6.0
1	40%		20.0%	1.00	2.00	4.5
1	20%		10.0%	0.50	1.00	2.5
2	100%	100%	75.0%	3.75	7.50	12.0
2	80%		60.0%	3.00	6.00	9.5
2	60%		45.0%	2.25	4.50	7.5
2	40%		30.0%	1.50	3.00	6.0
2	20%		15.0%	0.75	1.50	3.5
3	100%	50%	83.3%	4.15	8.35	13.0
3	80%		66.7%	3.35	6.65	10.5
3	60%		50.0%	2.50	5.00	8.5
3	40%		33.3%	1.65	3.35	6.0
4	100%	33%	87.5%	4.40	8.75	13.5
4	80%		70.0%	3.50	7.00	11.5
4	60%		52.5%	2.65	5.25	9.0
4	40%		35.0%	1.75	3.50	6.0
5	100%	25%	90.0%	4.50	9.00	14.0
5	80%		72.0%	3.60	7.20	11.5
5	60%		54.0%	2.70	5.40	9.0
5	40%		36.0%	1.80	3.60	6.5

Thyro-A 2A

Load with common star point and without neutral conductor

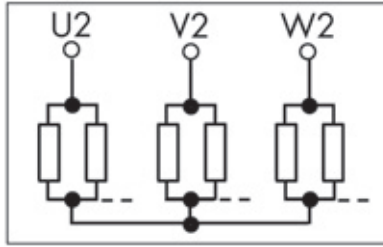

Tab. 7b Load with common star point and without neutral

		Thyro-A 2A load with common neutral point without N				
e.g. parallel load resistances	$\frac{I_{load\ nom.}}{I_{type\ contr.}}$	Resistance increase in case of fault	Recommended setting for Poti R205	X2.9 [V] [0-10V]	X2.9 [0-20mA]	ca. Revo-lutions
Number						
1	100%	Infinite	50,0%	2.50	5.00	8.5
1	80%		40,0%	2.00	4.00	7.0
1	60%		30,0%	1.50	3.00	6.0
1	40%		20,0%	1.00	2.00	4.5
1	20%		10,0%	0.50	1.00	2.5
2	100%	67%	80,0%	4.00	8.00	12.0
2	80%		63,0%	3.15	6.30	10.0
2	60%		48,0%	2.40	4.80	8.0
2	40%		32,0%	1.60	3.20	5.5
2	20%		16,0%	0.80	1.60	3.5
3	100%	33%	87,0%	4.35	8.70	13.5
3	80%		70,0%	3.50	7.00	11.5
3	60%		52,0%	2.60	5.20	8.5
3	40%		35,0%	1.75	3.50	6.0
4	100%	22%	90,0%	4.50	9.00	14.0
4	80%		72,0%	3.60	7.20	11.5
4	60%		(54%)	2.70	5.40	9.0
4	40%		-	-	-	-

EN

For Thyro-A 2A (with load in delta connection) a setting for load monitoring can be made according to the table below:

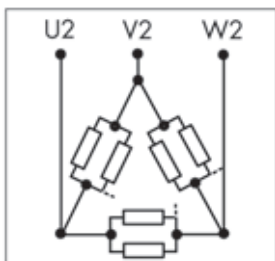

Tab. 7c Load monitoring

		Thyro-A 2A Load in delta connection				
e.g. parallel load resistors	$I_{load\ nom} / I_{type\ controller}$	Resistance increase in case of fault	Recommended setting for Poti R205 in %	X2.9 [V] [0-10V]	X2.9 [0-20mA]	ca. turns
number						
1	100%	73%	79.0%	3.95	7.90	12.0
1	80%		63.0%	3.15	6.30	10.0
1	60%		48.0%	2.40	4.80	8.0
1	40%		32.0%	1.60	3.20	5.5
1	20%		16.0%	0.80	1.60	3.5
2	100%	31%	88.0%	4.40	8.80	13.5
2	80%		66.0%	3.30	6.60	10.5
2	60%		50.0%	2.50	5.00	8.5
2	40%		33.0%	1.65	3.30	6.0
2	20%		17.0%	0.85	1.70	4.0
3	100%	20%	90.0%	4.50	9.00	14.0
3	80%		72.0%	3.60	7.20	11.5
3	60%		(54%)	2.70	5.40	9.0
-	-		-	--	-	
-	-		-	--	-	
-	-	-	-	--	-	
-	-		-	--	-	

Thyro-3A

Load with common star point and without neutral conductor

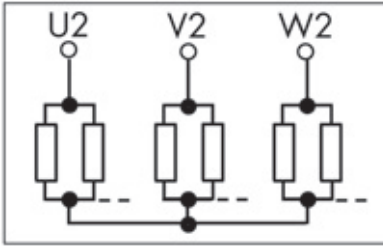

Tab. 8 Load with common star point and without neutral conductor

No. of parallel load resistors	$I_{load\ nom} / I_{type\ controller}$ in %	Current in the case of fault in %	Recommended setting for Poti R205 in %	Setting aid at actual value output X2.9 in mA	Setting aid at actual value output X2.9 in Volt	No. of potentiometer turns from left stop
1	100	0	50	5	2.5	7.8
	80		40	4	2	6.6
	60		30	3	1.5	5.4
	40		20	2	1	4.2
	20		10	1	0.5	2.9
2	100	60	80	8	4	11.4
	80		64	6.4	3.2	9.5
	60		48	4.8	2.4	7.5
	40		32	3.2	1.6	5.7
	20		16	1.6	0.8	3.7
3	100	75	87.5	8.75	4.375	12.3
	80		70	7	3.5	10.3
4	100	82	91	9.1	4.55	12.8

Load in delta connection

Thyro-3A

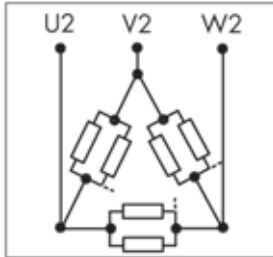

Tab. 9 Load in delta connection

No. of parallel load resistors	$I_{load\ nom} / I_{type\ controller}$ in %	Current in case of fault in %	Recommended setting for Poti R205 in %	Setting aid at actual value output X2.9 in mA	Setting aid at actual value output X2.9 in Volt	No. of potentiometer turns from left stop
1	100	57	78.5	7.85	3.925	11.3
	80		62.8	6.28	3.14	9.4
	60		47.1	4.71	2.355	7.5
	40		31.4	3.14	1.57	5.6
	20		15.7	1.57	0.785	3.7
2	100	76	88	8.8	4.4	4.0
	80		70.4	7.04	3.52	10.3

Thyro 3A

Load with common star point with neutral conductor (1)

Load with separate star point without neutral conductor (2)

Load in open delta connection (3)

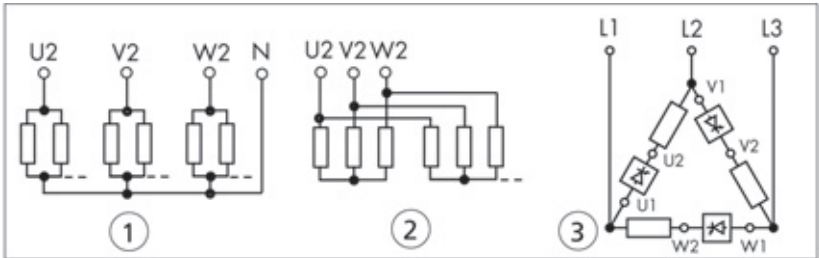

Tab. 10 Other possibilities of load monitoring

No. of parallel load resistors	$I_{load\ nom} / I_{type\ controller}$ in %	Current in case of fault in %	Recommended setting for Poti R205 in %	Setting aid at actual value output X2.9 in mA	Setting aid at actual value output X2.9 in Volt	No. of potentiometer turns from left stop
1	100	0	50	5	2.5	7.8
	80		40	4	2	6.7
	60		30	3	1.5	5.4
	40		20	2	1	4.2
	20		10	1	0.5	3.0
2	100	50	75	7.5	3.75	10.9
	80		60	6	3	9.0
	60		45	4.5	2.25	7.2
	40		30	3	1.5	5.4
	20		15	1.5	0.75	3.6
3	100	66	83	8.3	4.15	11.8
	80		66,4	6.64	3.32	9.8
	60		49,8	4.98	2.49	7.8
	40		33,2	3.32	1.66	5.9
	20		16,6	1.66	0.83	3.8
4	100	75	87,5	8.75	4.375	12.3
	80		70	7	3.5	10.3
	60		52,5	5.25	2.625	8.1
	40		35	3.5	1.75	6.0
	20		17,5	1.75	0.875	3.9
5	100	80	90	9	4.5	12.7

5. Installation



DANGER

Dangers during Installation

Risk of injury / Risk of damage to the device or plant
> Observe all safety regulations in the safety chapter



DANGER

Unsafe system due to incorrect installation

The plant cannot be operated safely and poses a threat to persons.

- > Only install the device in an upright position.
- > Ensure sufficient ventilation of the cabinet if mounted in a cabinet.
- > Observe minimum spacing (Clearance: 150 mm above, 100 mm below). The devices can be installed next to each other without spacing between.
- > Ensure that the device cannot be heated up by heat sources below it. (The power loss is given in the type overview table, see page 87, Technical data)
- > Ground the device in accordance with local regulations. (grounding screw / nut for protective conductor connection to fixing adapter). Grounding also serves for EMC means (Y capacitor 4.7 nF).



CAUTION

Use of incorrect connection cables

Incorrect connection cables can lead to malfunctions.

Use shielded control conductors to connect the control signals.

For use in UL conditions: Only use 60°C or 75°C copper conductors for power connections (as indicated in Technical Data).



NOTE

Connecting the control signals

The following control signals are necessary for operating the devices:

- Setpoint (terminal X2.4 or via bus option)
- Pulse inhibition (to ground, on terminal X2.1, X2.2; bridge present)

If the pulse inhibition bridge is not connected, the device is blocked and is not operating. Communication is still possible via the interface (see page 63, Connecting pulse inhibition).

The device is parameterised when delivered and also adapted to the particular power unit.

Default setting:

- Operating mode VAR (S1.1 and S1.2)
- Transformer load R201 90°el. / 60°el. (depending on the type of device)

Other default settings are listed in the chapter Operation and Settings (DIP switches (see page 39, DIP switch S1) and potentiometers (see page 44, Potentiometer).

> Check default settings and adjust to application conditions if necessary (e.g. operating mode, control mode, restrictions, monitoring, analog output, fault messages etc.)

The devices can be installed next to each other without spacing between.

Observe minimum spacing (free space: 150 mm above, 100 mm below).



















5.1 Connecting terminals (Overview)

Tab. 11 Connecting terminals (Overview)

Terminal	Description	Grid dimension	
X3*	.3	N/C contact, closed when there is a fault	5.08
	.2	N/O contact, open when there is a fault (closed circuit principle)	
	.1	Root, common connection	
X22	.7	Control ground	3.5
	.6	Connection to slave	
	.5	Connection to slave	
	.4	Control ground	
	.3	RxD / Connection to bus module	
	.2	TxD / Connection to bus module	
	.1	Bus module detection / setpoint selection	
X2	.10	Ground potential, maybe shield control conductor	3.5
	.9	Analog output 0-10V or 0(4)-20mA	
	.8	+ 5V output e.g. for a setpoint potentiometer ($5k\Omega \leq R_{Pot} \leq 10k\Omega$)	
	.7	Sync. In (SYT-9)	
	.6	Sync. Out	
	.5	Control ground	
	.4	Analog setpoint input max. 10V, max. 20mA	
	.3	Control ground	
	.2	Pulse inhibition (PULSE INHIBIT)	
	.1	Control ground	
X11*	.2	24V extra electronics supply AC or - DC	3.5
	.1	24V extra electronics supply AC or + DC	
X1	.2	Works connection (do not alter!)	
	.1		

* only for ...H RL1 and ...H RLP1

Fig. 2 Operating elements

	H 100	LED	gn	ON	
	H 101	LED	rt	PULSE INHIBIT	
	H 250	LED	rt	LOAD FAULT	
	H 350	LED	gn	Diagnosis/percent modulation indication	
	S1.10	Analog output	10V / 20mA		Chap. 4.2.4
	S1.9	Live Zero analog output			
	S1.8	Setpoint value input			Chap. 4.2.3
	S1.7	Setpoint value input			
	S1.6	Live Zero setpoint			Chap. 4.2.3
	S1.5	Control mode / Thyro-Tool mode			Chap. 4.2.2
	S1.4	Control mode / Thyro-Tool mode			
	S1.3	Control mode / Thyro-Tool mode			
	S1.2	Operation mode			Chap. 4.2.1
	S1.1	Operation mode			
		Phase angle 1st for transformer	TRAFO ADAPTION		Chap. 4.3.1
	R 201	load	SCALE SETPOINT		Chap. 4.3.3
	R 202	Control end	CURRENT LIMIT		Chap. 4.3.4
	R 203	Current limit	SCALE OUTPUT		Chap. 4.3.6
	R 204	Increase Load monitoring	LOAD FAULT		Chap. 4.3.7

5.2 Connecting power supply

The power supply is connected in accordance with the figures and technical data and must be connected for Thyro-2A and Thyro-3A to a right rotating field in the power circuit. Thyro-1A must be connected to U1 / U2

- Switch off mains supply and secure against accidentally being switched back on.
- Remove the cover.
- Ground the power controller
- Connect the load to connection terminals U2, V2, W2.
- Connect terminals U1, V1, W1 to the circuit breaker.
- Make any other necessary connections.

The electronics of the control device are supplied directly from the power unit (terminals U1, X1.1 and X1.2). This voltage is used simultaneously for mains synchronization. The mains connection is designed for input voltages of $U_{nom} -15\%$ to $+10\%$ and nominal frequencies from 47Hz to 63Hz. Both terminals (X1.1 and X1.2 1.5 mm², grid 3.5) are bridged internally. When connecting a phase to X1 a fused connection is necessary (see Tab. 11, page 60).

Exception: When an additional electronics supply is connected.

5.3 Connecting additional electronics supply (only for ...H RL1 and ...H RLP1)

The thyristor power controller Thyro-A is equipped with an additional 24V AC/DC power supply input. (X11.1 and X11.2 1.5 mm², grid 3.5).

If needed, e.g. when operating with a bus, or voltages below the tolerance (e.g. when operating a 500V Thyro-A at a 440V mains) the control device can be supplied additionally with 24V AC or DC. The 24V voltage must be ungrounded (SELV) and must not be connected to the control ground. However, several Thyro-A can be operated on a 24V supply. The input is reverse polarity protected. The connection output for the control device is circa 2W (5VA) per controller.

The 24V connection lines are to be fused in accordance with the applicable regulations. A soldered in fuse protects the device in case of internal short-circuits.

5.4 Connecting pulse inhibition

Certain errors (see page 24, Error and status messages) trigger pulse inhibition internally. Triggering of pulse inhibition can be configured.

Preparing to use pulse inhibition

- Switch off mains supply and secure against accidentally being switched back on.
- Replace bridge from X2.1 to X2.2 with a switching contact (low-current contact).

Activating pulse inhibition (with device switched on)

- Open switching contact.
 - > Pulse inhibition is activated.
 - > Power unit is no longer addressed



NOTE

The contact for the activation of the pulse inhibition is to be set up as a low-current contact.

5.5 Connecting analog setpoint input

The setpoint input (terminals X2.3 ground – X2.4 + 1.5mm² grid 3.5) is suitable for process controllers with output signals from 0(4) – 20mA, 0-5V, 0-10V.

- Switch off mains supply and secure against accidentally being switched back on.
- Configure analog setpoint input (see page 43, Live zero and setpoint input range).
- Connect process controller (output signals of 0(4) - 20mA, 0 - 5V, 0 - 10V) to terminal X2.3 (ground) and X2.4 (+).

5.6 Connecting control input for switch operation

With a purely ohmic resistance load terminal X2.7 can be used as an additional digital „setpoint input“ (24V DC) so that Thyro-A, for example, can be triggered by a 2 point controller. In addition the potentiometer R201 must be turned to the left stop (angle 1 is deactivated) and Thyro-A then switches into a faster TAKT operation with $T_0 = 5$ periods without SST (Soft-start). At a signal level of > 3 volts at terminal X2.7 Thyro-A switches on (switch operation).

- Switch off mains supply and secure against accidentally being switched back on.

- Configure operating mode TAKT (see page 41, Operating mode and load type).
 - Turn potentiometer R201 TRAF0 ADAPTION to left stop (see page 44, potentiometer).
 - Connect signal generator (e.g. 2-point controller) to terminal X2.7.
- > The device switches on at a signal level of > 3 V

5.7 Connecting the bus module

The way in which the bus module is connected to the power controller decides the type of setpoint processing (see page 19, Setpoint processing). Terminal X22.1 controls the processes (we recommend the use of preassembled connection cable 2 000 000 848 / 849).

Setpoint of the analogue control terminal only

- Do not make any connections to terminal X22.1.
- > Only the analog signal (X2.4 (+); X2.3 (ground)) is used as setpoint.

Setpoint of bus module only

- Connect ground to terminal X22.1.
- > Only the value of the bus module is used as setpoint.

Defined setpoint for bus failure

There are two possibilities:

- Connect terminal X22.1 on the master of the power controller to terminals X1.1 ... X8.1 of the bus module.
- > Cable to X22.1 is switched in the event of a malfunction.
- > In the event of malfunctions along the bus line, the system automatically switches to the analog setpoint at the control terminals of the power controller.
- Connect terminal X22.1 on the master of the power controller to terminals X1.5 ... X8.5 of the bus module.
- > Cable to X22.1 is switched in the event of a malfunction.
- > Depending on the settings on the bus module:

In the event of malfunctions along the bus line, the system automatically switches to the analog setpoint at the control terminals of the power controller or the last setpoint is maintained. In addition to this, each device connected to the bus module can be enabled individually via the bus on „Hand“ (see bus module instructions).

5.8 Using the analog output

(only for ...H RL1 and ...H RLP1)

- Switch off mains supply and secure against accidentally being switched back on.
- Connect terminals X2.9 (+) and X2.5 (ground) to a display device. Ensure the correct polarity!
- Configure the signal level (see page 41, Analog output).
- Adapt the signal level to the scale (see page 43, Analog output (Adapting scale)).

5.9 Using the THYRO-TOOL FAMILY

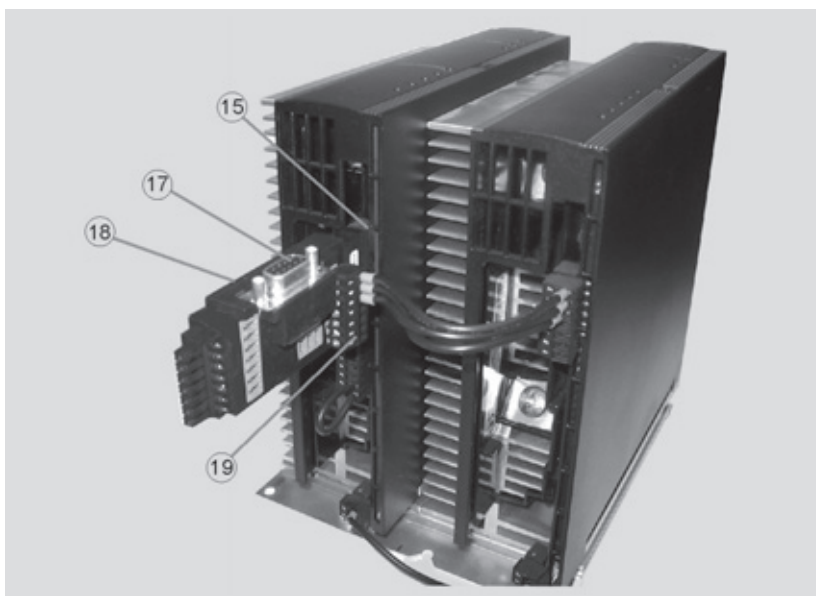

- 15 Terminal X22
- 17 Serial interface (COM) RS232
- 18 PC-Interface RS232
- 19 Connector (Connection to Slave only necessary for Thyro-2A and Thyro-3A)

- Switch off mains supply and secure against accidentally being switched back on.
 - Remove connector (connection to slave) of terminal X22.
 - Plug PC interface RS232 with the „Thyro-A“ side into terminal X22.
 - Plug in connector (connection to slave) at PC interface RS232.
 - Connect serial interface (COM) to PC using RS232 data cable (Order no.: 0048764; not crossed; connections 2,3,5,4 and 7 used).
- > The device can be operated with the THYRO-TOOL FAMILY. Measured values and parameters are displayed in the software. Extended functions can be set (see page 33, Extended functions).
- > Only for operation of the device in Thyro-Tool mode (S1.3 to S1.5 to ON): All parameters can be set with the THYRO-TOOL FAMILY.



NOTE

Switching over defined setpoint on the PC interface

A switch can be connected to terminals X1.2 and X1.3 of the PC interface RS232 to switch over the defined setpoint.

- For contact X1.2 with X1.3: Digital defining of setpoint with THYRO-TOOL FAMILY and temporary Thyro-Tool mode.
- For no contact X1.2 with X1.3: Analog defining of setpoint with terminal X2.4 (see page 19, Setpoint processing)

Fig. 3 User surface THYRO-TOOL FAMILY

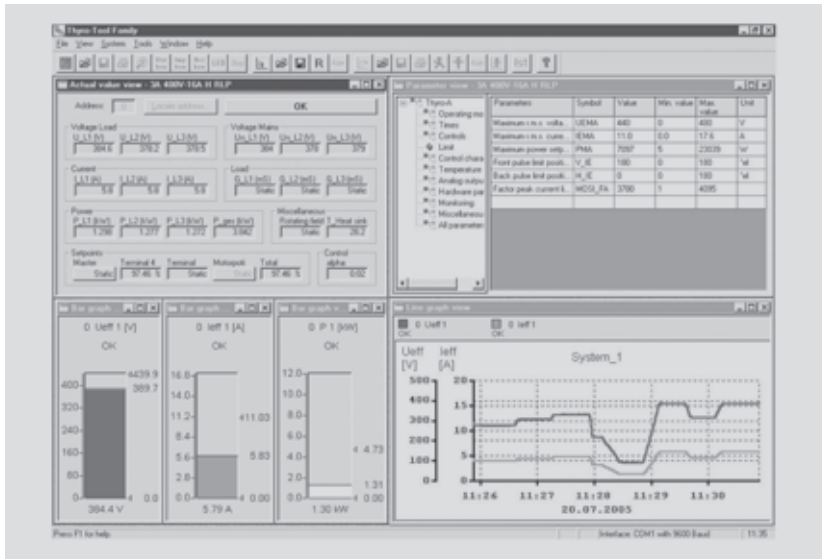

Power controllers of the Thyro-A series can be operated conveniently with the PC software THYRO-TOOL FAMILY and settings can be made. The prerequisite for working with the THYRO-TOOL FAMILY is that there is a connection between the PC and power controller. This means that measured values can be visualized and parameters displayed. If the Thyro-A is not operated in Thyro-Tool mode, certain parameters can be altered. In Thyro-Tool mode, almost all parameters can be altered.

EN

6. Mains load optimization



DANGER

Danger when making adjustments

Risk of injury / Risk of damage to the device or plant

> Observe all safety regulations in the safety chapter.

Mains load optimization offers considerable advantages, e.g. reducing mains load peaks and system disturbances. Mains load optimization is possible under the following conditions:

- When more than one power controller is used
- Operating mode TAKT

The mains load is optimised by cascading the switching on of the individual devices. There are two different processes for doing so.

6.1 Internal mains load optimization

(Operating modes QTM (Thyro-1A) and TAKT)

In the operating modes QTM and TAKT the synchronization of 2-12 controllers is possible. The operating mode QTM works in a quick half wave switch principle with a pattern of switched and blocked half waves at a set time interval < 1 second, also known as T0. In order where possible to create in mains a balance from the start (not after T0) the individual controllers synchronize by offsetting themselves by a network period. The first of the controllers connected has the SYT input X2.7 bridged to +5V X2.8.

The following controllers get their signal to X2.7 from the sync. output X2.6 of the previous controller. At the last controller X2.6 is free. (Parallel series connection) (see figure 8, page 75).

6.2 Synchronization with Thyro – Power Manager

If power controllers are working in accordance with the full wave switch principle (TAKT) then this can lead to an increased mains load through an unfavourable spread of switching on and off times. This, as a result, then has negative effects such as higher power loss, flicker effects etc.

If load elements are used, whose resistances increases over time (ageing), then potentially a transformer with increased power output may even need to be implemented.

All of these negative effects can be avoided or reduced to a minimum level by using the Thyro-Power Manager.

The Thyro-Power Manager has a total of 10 digital outputs at the terminals (figure 12, page 78) X3 and X4. These are set up as potential-free optical coupler outputs. When optimising the network load they are used as synchronization outputs (SYT) for the connected power controllers or power controller groups. All cables are to be laid shielded with the shield grounded at the output switch. (Please find details in the Thyro-Power Manager operating instructions available separately)

Characteristics:

- Minimal mains peak load and realted mains feedback rates.
- Changes to the setpoint and load do not automatically feed into the mains load optimization.
- Can also be used in connection with already existing AEG power controllers.

6.3 Software synchronization (operating mode TAKT)

Software synchronization is a method of mains load optimization where an optional bus module is used or the THYRO-TOOL FAMILY. The software synchronization is set by entering a parameter (Parameter 36).

- Set the cycle period T_0 to the same value for all power controllers (recommended: $T_0=1$ sec.).

When setting with the bus module:

- Enter value via INDEX 38.

When setting with THYRO-TOOL FAMILY:

- Enter SYNC value „Synchro cycle address“. Select a different value for each power controller.
- > A delay period up to the first switching on is set. The value is multiplied by 10 ms.
- > The length of time up to the first switching on is different for each power controller.

This procedure allows the load to be connected slowly, e.g. with a slow cycle time of 1 sec. Values at intervals of 100 lead to a switch on delayed by a cycle period T_0 (group formation). This function allows an auxiliary power generator to be connected, for example.

Example: 4 controllers, e.g. with 100A, load triggering approx. 30% contents of Sync_Adr:0 (100), 25, 50, 75

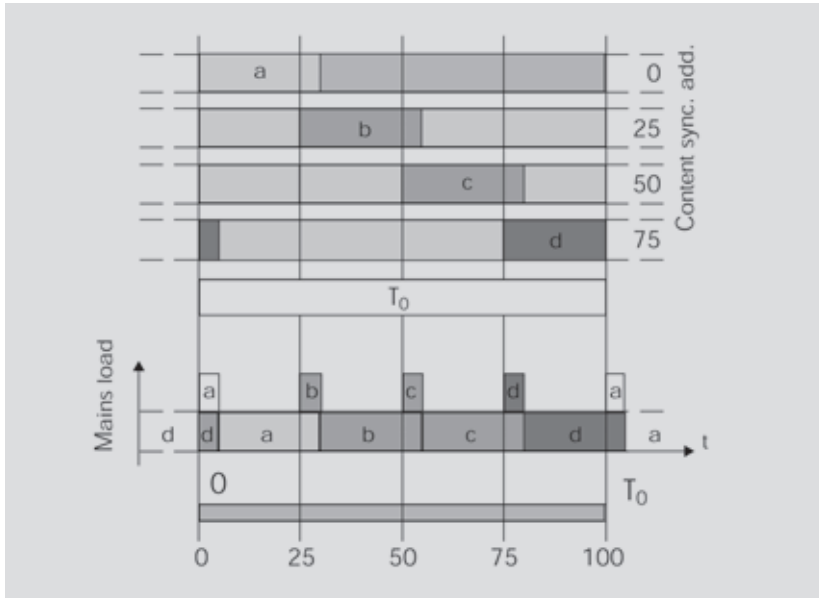

7. Connection diagrams

Fig. 4 Connection diagram Thyro-A 1A... H(F) 1

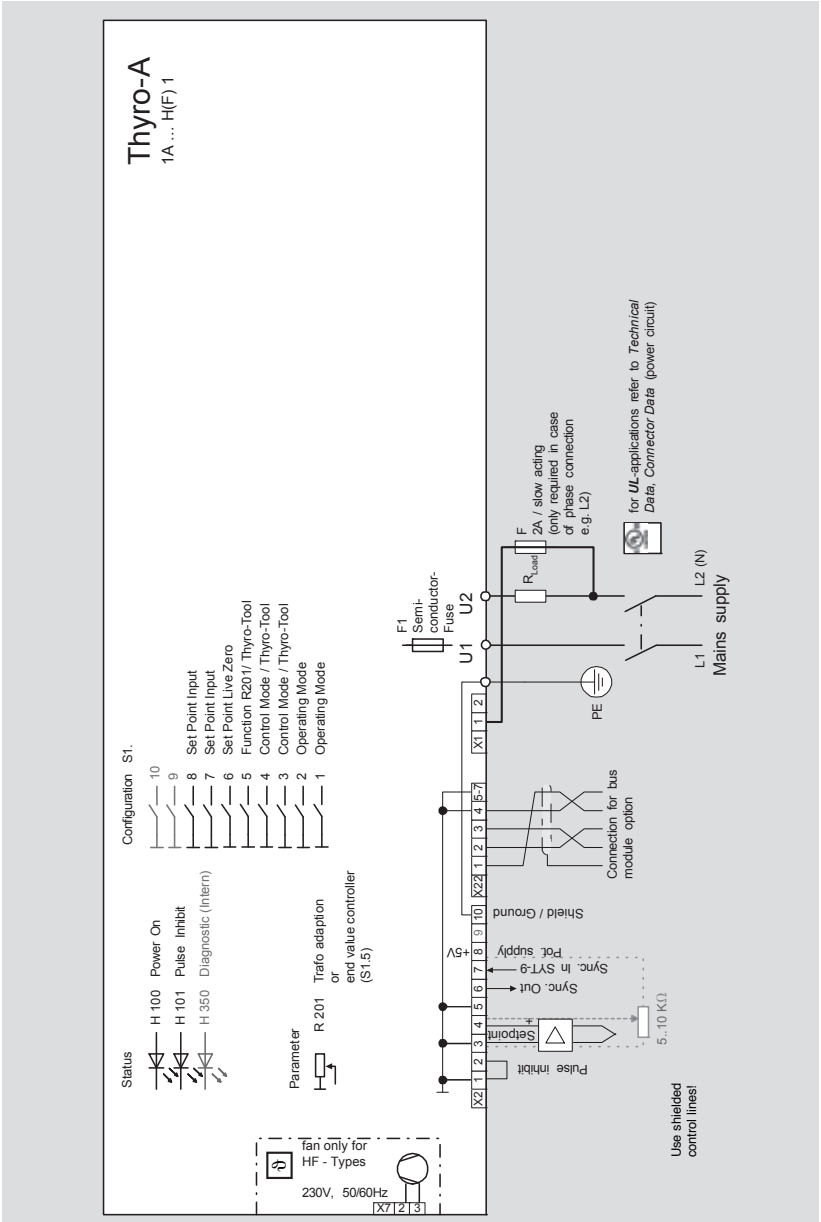

Fig. 5 Connection diagram Thyro-A 2A... H1

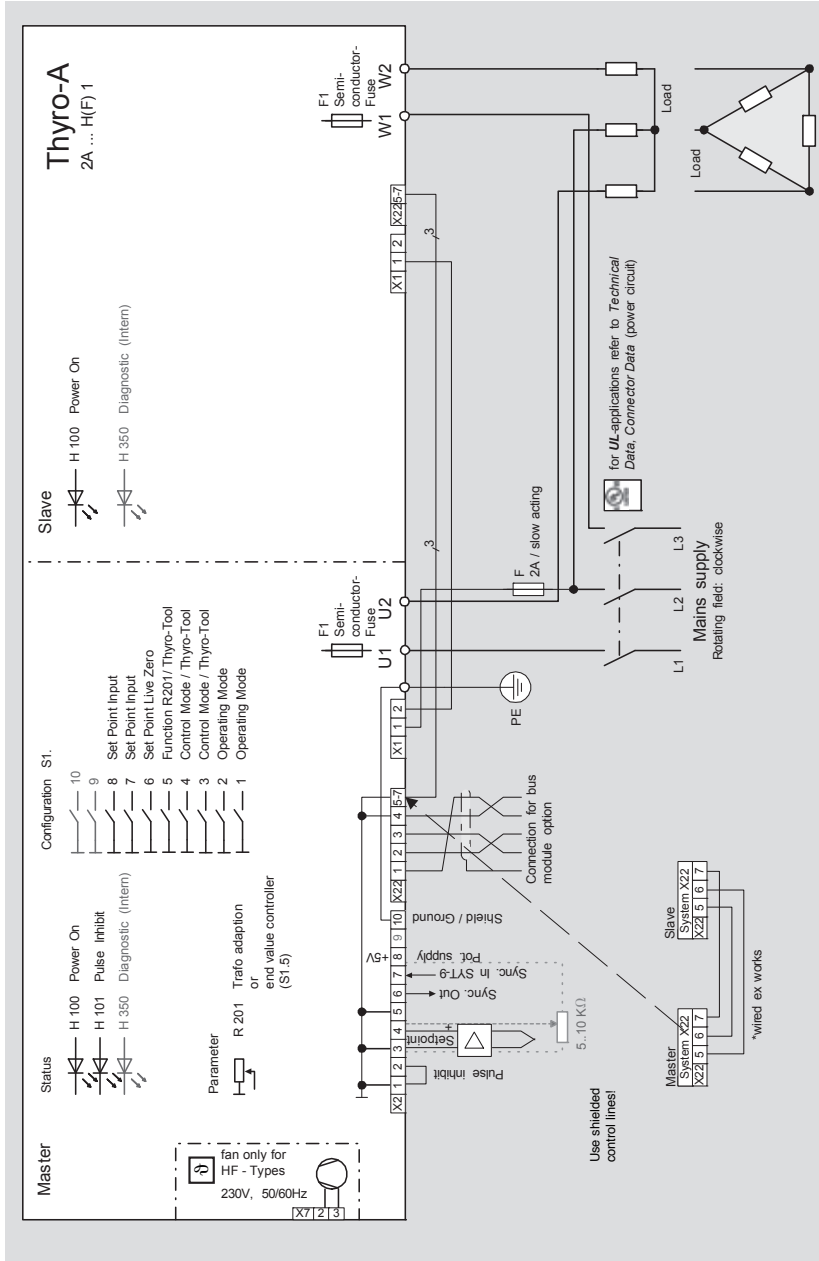

Fig. 6 Connection diagram Thyro-A 1A...H RL1, ...H RLP1

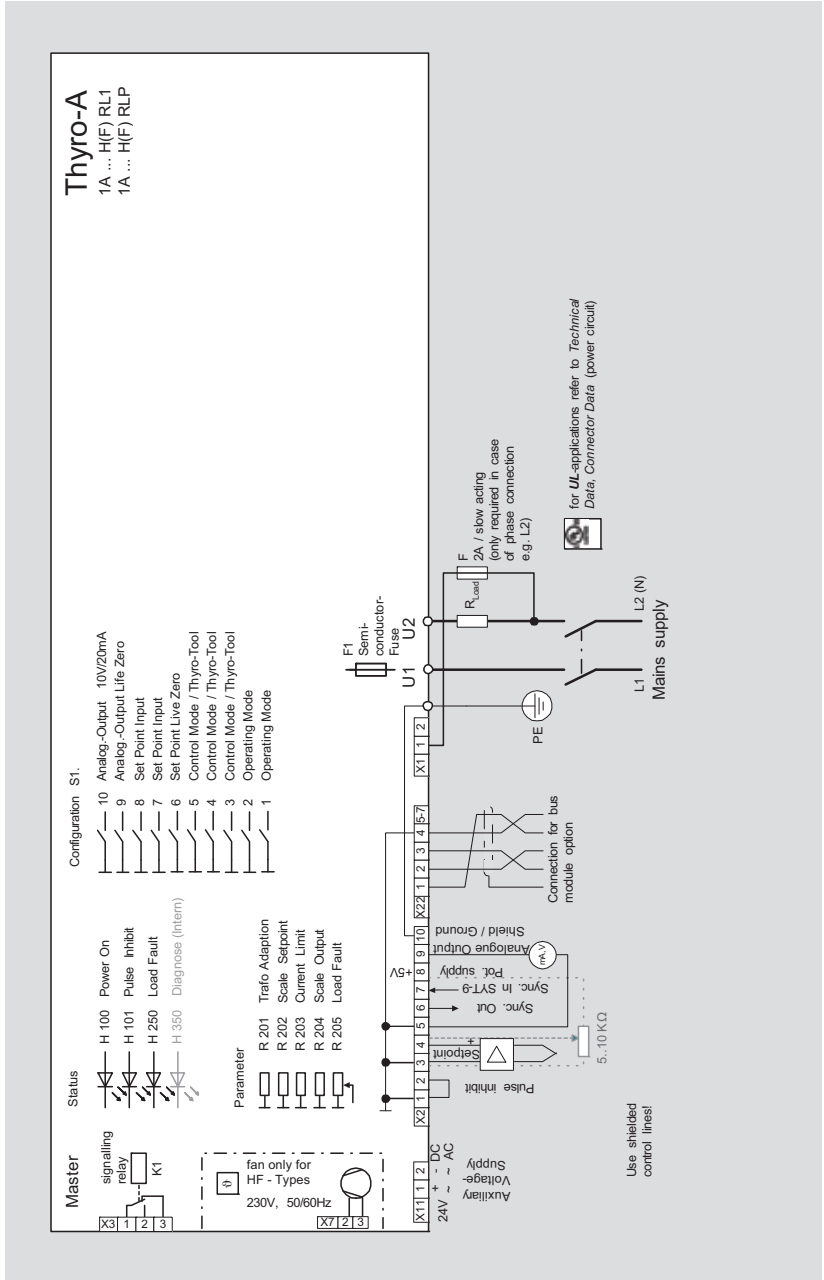

Fig. 7 Connection diagram Thyro-A 2A...H RL1, ...H RLP1

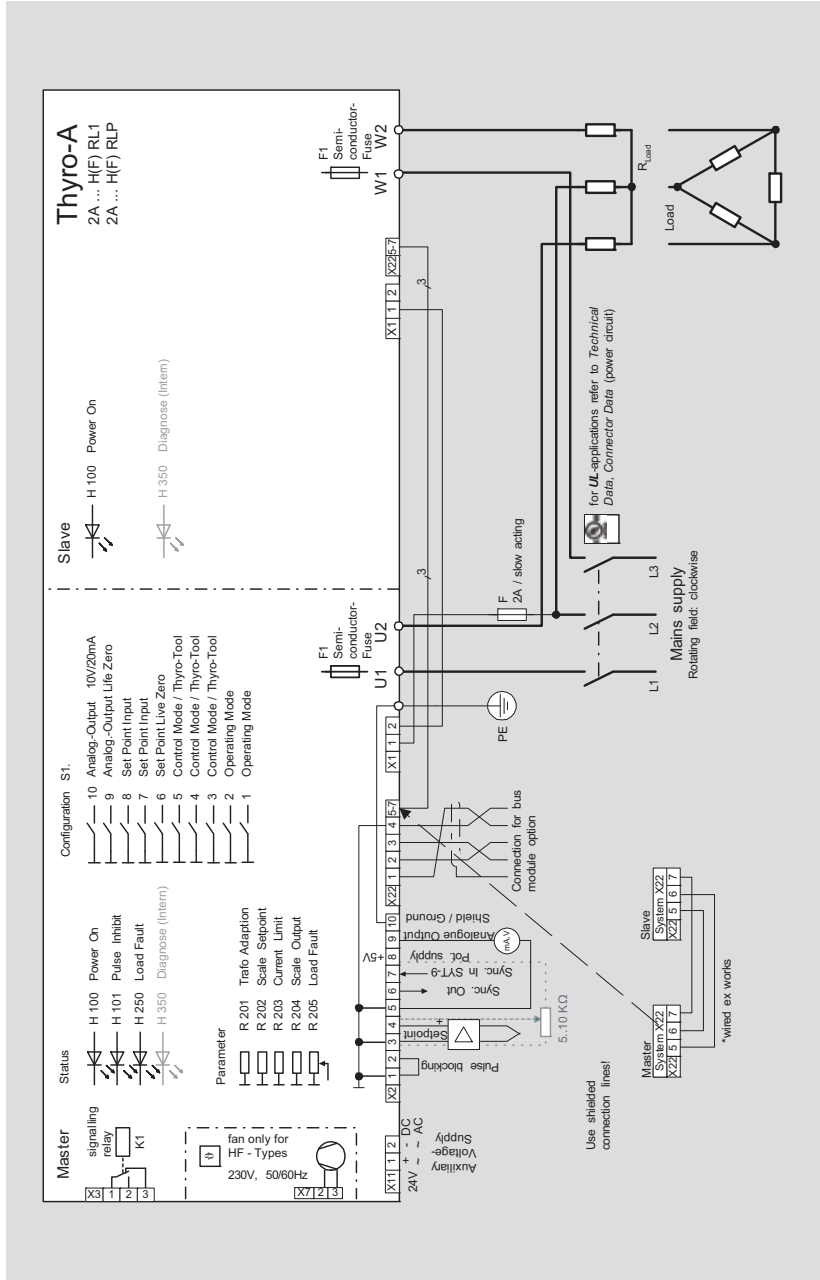
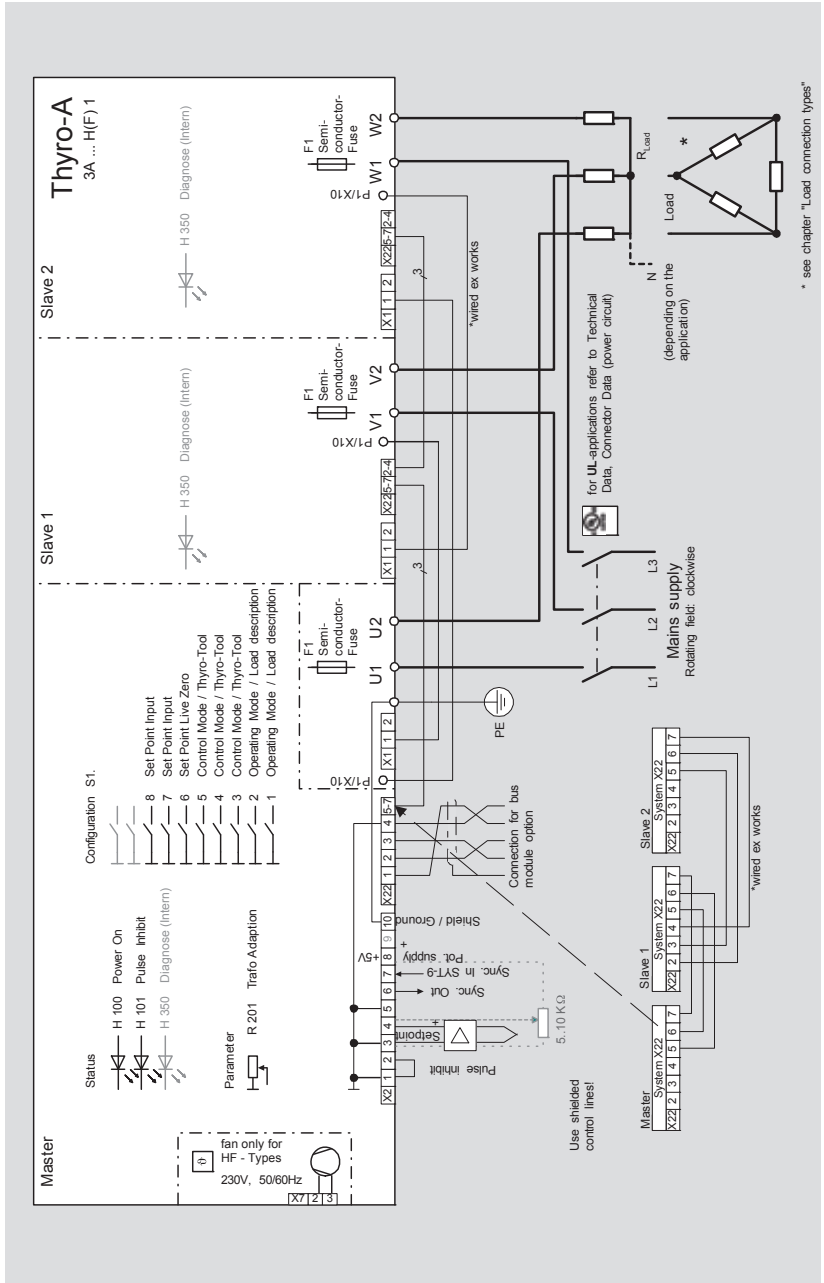

Fig. 8 Connection diagram Thyro-A 3A...H1



EN

Fig. 9 Connection diagram Thyro-A 3A...H RL1, ...H RLP1

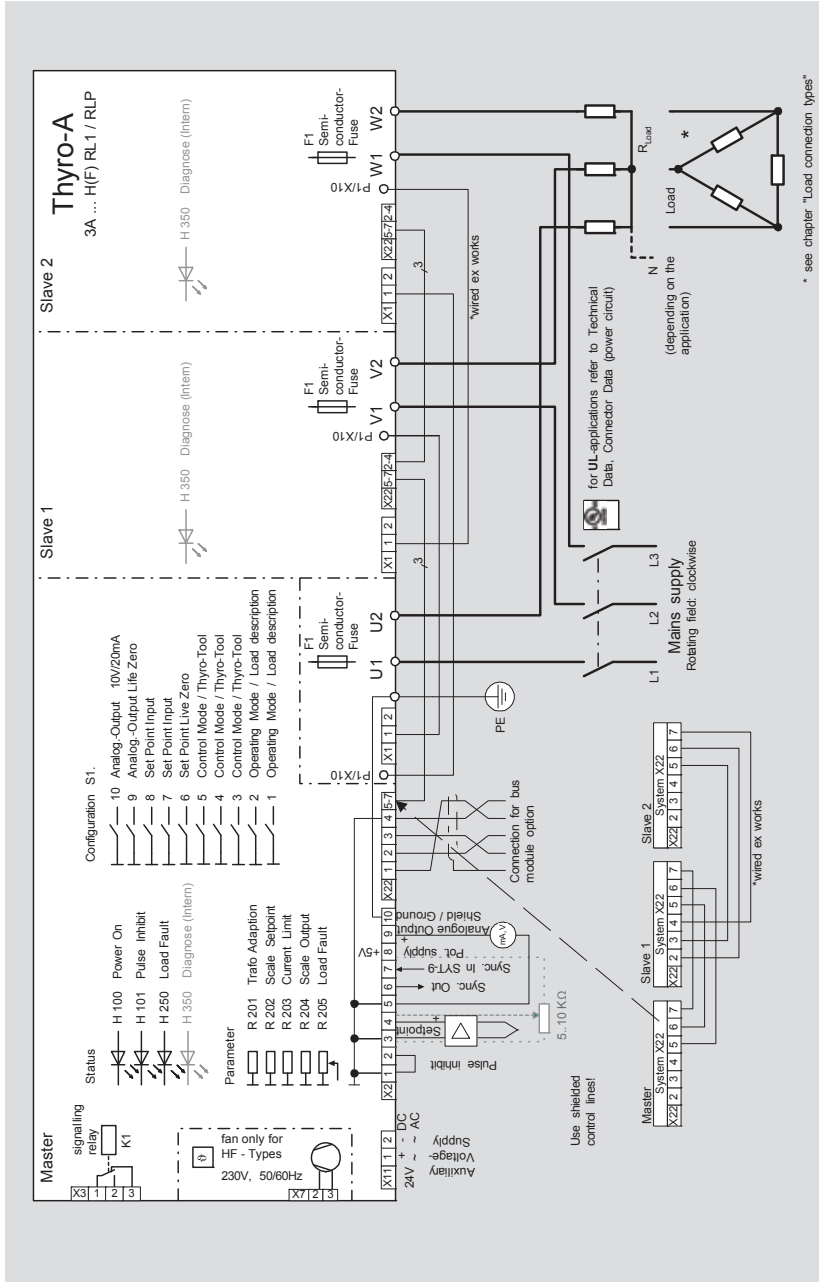
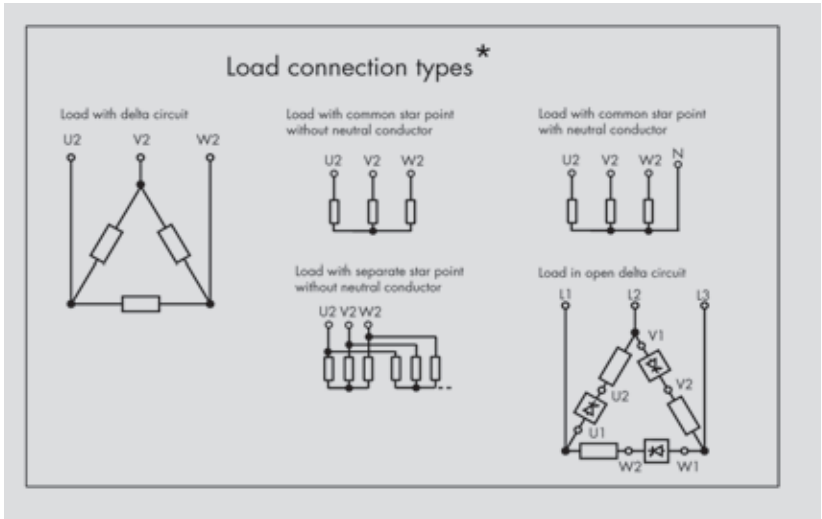
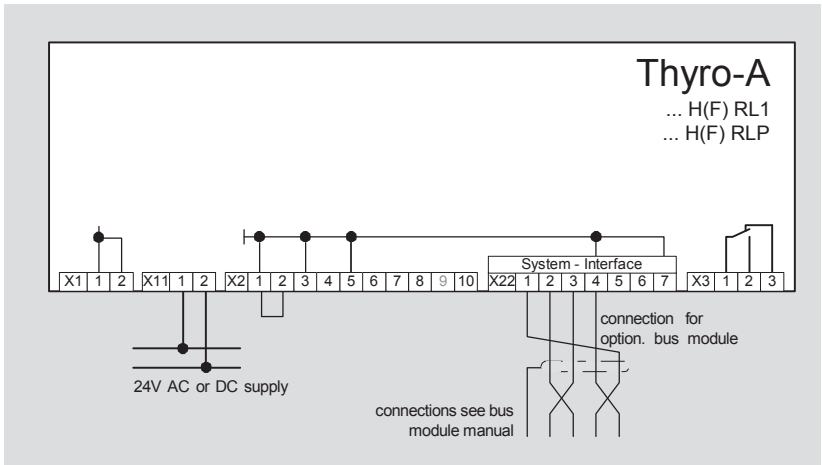

Fig. 10 Load connection types



* Pay attention to setting (S1.1 and S1.2)

Fig. 11 Additional electronics supply and connection with optional bus module



EN

Fig. 12 Connection diagram mains load optimization with Thyro-Power Manager

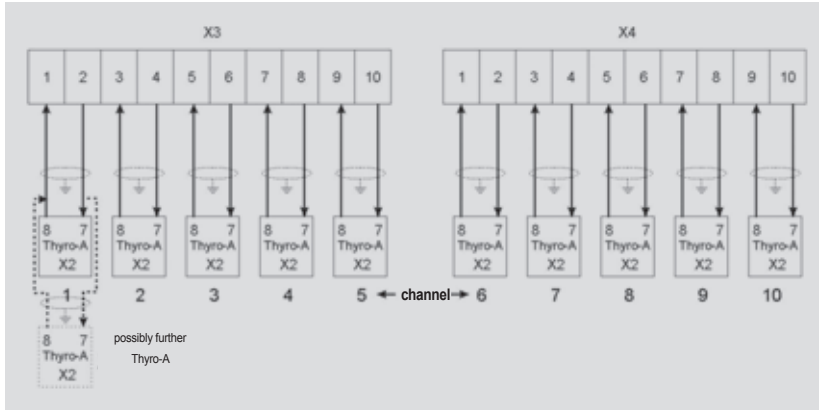
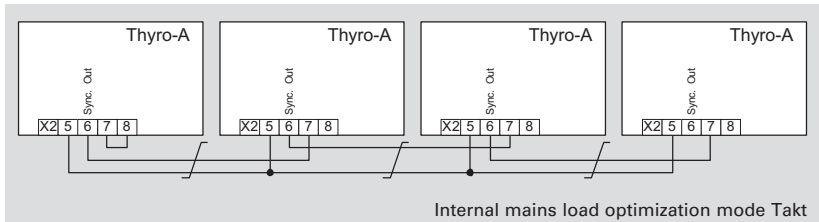

Fig. 13 Connection diagram mains load optimization for operating mode TAKT



8. Help in the event of problems

The devices delivered correspond to quality standard ISO 9001. Should you experience any malfunctions or other problems, please contact our 24-hour service hotline (Tel.: +49 / 2902 / 763-100). Please also see contacts on page 6.

Here are several tips to help resolve problems:

Error : LED ON green does not light up or LED „pulse inhibit“ flashes slowly

• Check power unit fuse F1:

If the fuse is defective :

- Check if there is a short-circuit at the load or wiring.
- Check the type of load. When setting for an ohmic load and using a transformer load the fuse F1 can be tripped by too high rush currents.
- With high temperature elements with a larger $R_{\text{warm}} / R_{\text{cold}}$ ratio you must check that in operating mode TAKT the switch-on current does not exceed the rated current of the device.
- With a transformer load an alloyed thyristor can generate a pulsed DC voltage and thus lead to a case of fusing. Check with an ohmic load e.g. 100W light bulbs single-phase / in star connection.

• Check microfuse F2:

If the fuse is defective :

- Replace defective fuse (500V 1.6A T). Also check the fuse in cases of faults with the external fuse if present.
- Check SYNC voltage:
- Check if the synchronization voltage at the affected module is available between the microfuse and the terminal X1.1 at the affected module. As long as the fuses of the module are consistent the voltage can alternatively be measured between U1 and X1.1,...

Error: LED ON green lights up and the power output is too low

• Check „Pulse Inhibit“:

If the LED „Pulse Inhibit“ lights up:

- X2.1, X2.2. must be connected (hardware obstruction).
- If the LED „Load Fault“ lights up at the same time there is a case of undervoltage.

• Check trigger pulse:

The internal diagnosis LEDs „H350“ of all modules of a controller flash simultaneously corresponding to power output as pulse width modulation in TAKT operation and as a flash frequency in VAR operation. As long as these diagnosis LEDs show a trigger pulse dependent on the setpoint, then the setpoint setting and the adjustment of the device is OK. The connection to the load is probably not intact or there is a load interrupt. If the load does not reach the necessary power, even though the H350 LEDs of the controller are already shining constantly (100% level control, full mains voltage at the load) then the load or the transformer is not properly dimensioned or the load has increased the resistance through ageing. An intermittent flashing of the Pulse Inhibit and Load Fault LEDs indicates an active limitation value.

• Check setpoint value/control value:

- Check setpoint setting at terminal X2.4 (+) against X2.3 (ground). When using the analog setpoint value make sure the DIP switches 6,7,8 are set up correctly, even if the device is operated in Thyro-Tool Mode. A 5...10kOhm potentiometer at X2.1 and X2.8 when the DIP switches 6,7,8 are set up at 0...5V can be connected to X2.4 with wipers as a test setpoint value transmitter. When using a bus setpoint value make sure the setpoint value is activated with appropriate wiring to X22 in accordance with the bus manual.
- Check if the „H350“ LEDs indicate the current degree of level control; see „check trigger pulse“. Through varying the setpoint value the device must be capable of being operated from 0% to 100% level control, as long as no limitation is desired.
- Check if the maximum control value/control limit via (R203) or via the software is set at the correct parameter.

- **Check wiring:**

- Check if the wiring of terminal X1.1 is correct, that the mains is connected to terminals U1 (V1, W1 if present) and the load is connected to U2 (V2, W2). In the case of incorrect wiring it may be that the device only works with small setpoint values and switches to failure with larger setpoint values.

- **Check load of the output:**

- Check the load at the 5V DC output. Minimum resistance: $R_{min} = 5k\Omega$.
- Check all parallel load resistors for current flow.

Error: Load current flows without triggering

- **Check „Live Zero“:**

- Check the alignment of the control characteristics (U, I, live Zero). If the input is set to 0-20mA, but the setpoint value however is 4-20mA, then the controller will always adjust.

- **Check thyristor for short circuit:**

- Check if a pulsed amount of DC is outputted. Test device with a test load: e.g. 100W light bulbs single phase / in star connection.

9. Technical data

Type voltage ...H1

230V -57%* +10% > 99V

400V -57%* +10% > 172V

500V -57%* +10% > 215V

600V -57%* +10% > 258V

* The 5 V voltage (for possible setpoint potentiometer supply) on terminal X2.8 only works correctly in the -15% to + 10% range of the type voltage.

Type voltage ...H RL1 and ...H RLP1 without additional 24V electronics supply

230V -15% +10%

400V -15% +10%

500V -15% +10%

600V -15% +10%

Type voltage ...H RL1 and ...H RLP1 with additional 24V electronics supply

230V -57% > 99V

400V -57% > 172V

500V -57% > 215V

600V -57% > 258 V

Additional electronics supply

The additional control voltage supply can be AC or DC (2 W per device / 5VA / not grounded).

Normally the supply of the Master modules is sufficient.

24VAC +10% /-20%

24VDC +18V to +32V

Mains frequency

All types 47 Hz to 63 Hz;

Max. frequency change 5% per half wave

Load type

ohmic load

ohmic load with R_{warm}/R_{cold} ratio up to 6, peak current limiting to $\hat{I}=3xI_{nom}$ (for ...H RLP1 + HRL 1 in VAR operation)

Transformer load

Thyro-A 2A: symmetrical load

CAUTION



If grain oriented, cold rolled sheet metal is used, the induction of the downstream transformer should not exceed 1.45 T for mains overvoltage = 1.2 T nominal induction.

Operating modes

TAKT = Full wave switch principle

VAR = Phase angle principle

QTM = Half wave switch principle (Quick Takt Mode)
(only for types 1A)

Setpoint inputs

2 setpoint inputs (SELV, PELV), isolated from the system.

- Setpoint 1: analog setpoint input

Signal ranges:

0(4) - 20mA R_i = approx. 250 Ω

0(1) - 5V R_i = approx. 44k Ω

0(2) - 10V R_i = approx. 88k Ω

- Setpoint 2: optional bus interface, connection of higher level PC or automation system

Control characteristic

Each controller (e.g. temperature controller), with an output signal in the range of 0-20mA / 0-5V / 0-10V, can be adapted to the power controller.

Control input for switching mode

Maximum switching frequency 5Hz

$t_{on\ min}$ = 100ms

$t_{off\ min}$ = 100ms

Analog output (only for ...H RL1 and ...H RLP1)

Signal level 0-10V, 2-10V 0-20mA, 4-20mA

Maximum load voltage 10V

Control modes

...H1 (without current transformer): voltage control U_{eff} , U_{eff}^2

...H RL1 (with current transformer): voltage control U_{eff} , U_{eff}^2

current control I_{eff} , I_{eff}^2 ...

H RLP1 (with power control): voltage control U_{eff} , U_{eff}^2

current control I_{eff} , I_{eff}^2

power control P

Accuracy of control

Voltage $\pm 3\%^*$

In the -15% to $+10\%$ range of the type voltage.

Current $\pm 1.5\%^*$

*always based on the end value

Limits

Voltage limit U_{eff}

Current limit I_{eff} (for ...HRL1; ...HRLP1)

Power limit P (for ...HRLP1)

Peak current limit to $\hat{I}=3 \times I_{\text{nom}}$ at VAR mode

(for ...HRL1; ...HRLP1)

Relay outputs (only for ...H RL1 and ...H RLP1)

Changeover contact, contact material: AgSnO₂ / Au plated

The relay can be used for low load circuits ($> 5V$ 20mA), provided it has not been preloaded with 230VAC.

Max. values: 250V, 6A, 180W, 1500VA

Insulation resistance 4kV / 8mm

Ambient temperature

35°C at ...F... (with forced cooling)

45°C with natural air cooling (without fan)

If the maximum ambient temperature is reduced, the maximum load current can be increased up to 110% of the nominal current. The following applies: 1% more current requires a temperature reduction of 1°C.

The maximum ambient temperature can be increased up to a maximum of 55°C if the maximum load current is reduced. The following applies: 1°C more ambient temperature requires a current reduction of 2%. Use of the device in UL conditions up to a maximum ambient temperature of 40°C.

Connection data, power connection

Grounding screw / nut for connecting the protective conductor to the fixing adapter. Grounding also serves for EMC means (Y capacitor 4.7 nF).

	Connection U1, V1, W1, U2, V2, W2	Grounding screw	Conductor cross section
16 / 30A	lug / M4	lug / M4	max. 6 mm ²
45A*	M 6	M 6 max.	50 mm ²
60* / 100A*	M 6	M 6 max.	50 mm ²
130 / 170A	M 8	M 10	95 / 120 mm ²
280 A	M 10	M 10	150 / 185 mm ²
350A	M 10	M 10	185 mm ²
495A	M 10	M 10	Cu 48x3; 2xØ11
650A	M 10	M 10	Cu 48x3; 2xØ11
1000A	M12	M12	Cu 60x10; 2xØ14
1400A	M12	M12	Cu 60x10; 2xØ14
1500A	M12	M12	Cu 60x10; 2xØ14

In UL applications, use only 60°C or 60°C/75°C copper conductors (except for control lines).

* In UL applications, use only 75°C copper conductors (except for control lines).

Torques in Nm

Screw	Min. value	Nom. value	Max. value
M 2	0.22	0.25	0.28 (Phoenix terminals)
M 4	0.85	1.3	1.7
M 6	2.95	4.4	5.9
M 8	11.5	17	22.5
M 10	22	33	44
M 12	38	56	75

Fan data

230V, 50-60Hz

Thyro-A	Type current 50Hz	Type current 60Hz	Air volume	Noise level
1A...280 F	0.22A	0.22A	120 m ³ /h	67dB(A)
1A...350 F	0.22A	0.22A	120 m ³ /h	67dB(A)
1A...495 F	22W at 115/230V and/or 50/60Hz		288m ³ /h	58dB(A)
1A...650F	22W at 115/230V and/or 50/60Hz		288m ³ /h	58dB(A)
1A...1000F	0.29A	0.35A	880m ³ /h	58dB(A)
1A...1400F	0.29A	0.35A	880m ³ /h	58dB(A)
1A...1500F	0.29A	0.35A	880m ³ /h	58dB(A)
2A...280F	0.50A	0.38A	200m ³ /h	70dB(A)
2A...350F	0.50A	0.38A	200m ³ /h	70dB(A)
2A...495 F	0.31A	0.25A	380 m ³ /h	49dB(A)
2A...650 F	0.31A	0.25A	380m ³ /h	49dB(A)
2A...1000 F	0.56A	0.79A	1970m ³ /h	69dB(A)
2A...1400 F	0.56A	0.79A	1970m ³ /h	70dB(A)
2A...1500 F	0.56A	0.79A	1970m ³ /h	70dB(A)
3A...280 F	0.38A	0.38A	260m ³ /h	70dB(A)
3A...350 F	0.50A	0.38A	260m ³ /h	70dB(A)
3A...495 F	0.29A	0.35A	880m ³ /h	58dB(A)
3A...650 F	0.29A	0.35A	880m ³ /h	58dB(A)
3A...1000 F	0.56A	0.79A	1970m ³ /h	69dB(A)
3A...1400 F	0.56A	0.79A	1970m ³ /h	70dB(A)
3A...1500 F	0.56A	0.79A	1970m ³ /h	70dB(A)

The fans must run when the device is on, connection to X7.

Type overview

Thyro-A 1A...H1, ...H RL1, ...H RLP1

Current [A]	Type power [kW]				Power loss [W]	Dimensions in mm / kg				
	230V	400V	500V	600V		W	H	D	Weight	Fuse F1
16	3.7	6.4	8		30	45	131	127	0.7	20
30	6.9	12	15		47	45	131	127	0.7	40
45	10	18	22.5		48	52	190	182	1.7	63
60	14	24	30		80	52	190	182	1.7	80
100	23	40	50		105	75	190	190	1.9	200
130	30	52	65		150	125	320	241	4	200
170	39	68	85		210	125	320	241	4	315
280	64	112	140		330	125	370	241	5	350
350	80	140	175		390	125	400	261	8.4	500
495		198	247	297	603	112	414	345	15	630
650		260	325	390	726	112	414	345	15	900
1000		400	500	600	1396	239	729	516	35	2x1000
1400			700	840	1715	239	729	516	35	4x900
1500		600			1755	239	729	516	35	4x900

Thyro-A 2A... H1, ...H RL1, ...H RLP1

Current [A]	Type power [kW]			Power loss [W]	Dimensions in mm / kg				
	400V	500V	600V		W	H	D	Weight	Fuse F1
16	11	14		60	90	131	127	1.4	20
30	21	26		94	90	131	127	1.4	40
45	31	39		96	104	190	182	3.4	63
60	42	52		160	104	190	182	3.4	80
100	69	87		210	150	190	190	3.8	200
130	90	112		300	250	320	241	8	200
170	118	147		420	250	320	241	8	315
280	194	242		660	250	393	241	11	350
350	242	303		780	250	430	261	16.7	500
495	343	429	514	1206	194	380	345	22	630
650	450	563	675	1453	194	380	345	22	900
1000	693	866	1039	2811	417	685	516	54	2x1000
1400		1212	1454	3451	417	685	516	54	4x900
1500	1039			3531	417	685	516	54	4x900

Thyro-A 3A...H1, ...H RL1, ...H RLP1

Current [A]	Type power [kW]			Power loss [W]	Dimensions in mm / kg				Fuse F1
	400V	500V	600V		W	H	D	Weight	
16	11	14		90	135	131.6	127	2.1	20
30	21	26		141	135	131.6	127	2.1	40
45	31	39		144	156	190	182	5.1	63
60	42	52		240	156	190	182	5.1	80
100	69	87		315	225	190	190	5.7	200
130	90	112		450	375	320	241	12	200
170	118	147		630	375	320	241	12	315
280	194	242		990	375	397	241	15	350
350	242	303		1170	375	430	261	25.5	500
495	343	429	514	1822	276	407	345	30	630
650	450	563	675	2192	276	407	345	30	900
1000	693	866	1039	4127	583	685	516	74	2x1000
1400		1212	1454	5086	583	685	516	74	4x900
1500	1039			5206	583	685	516	74	4x900

10. Type overview

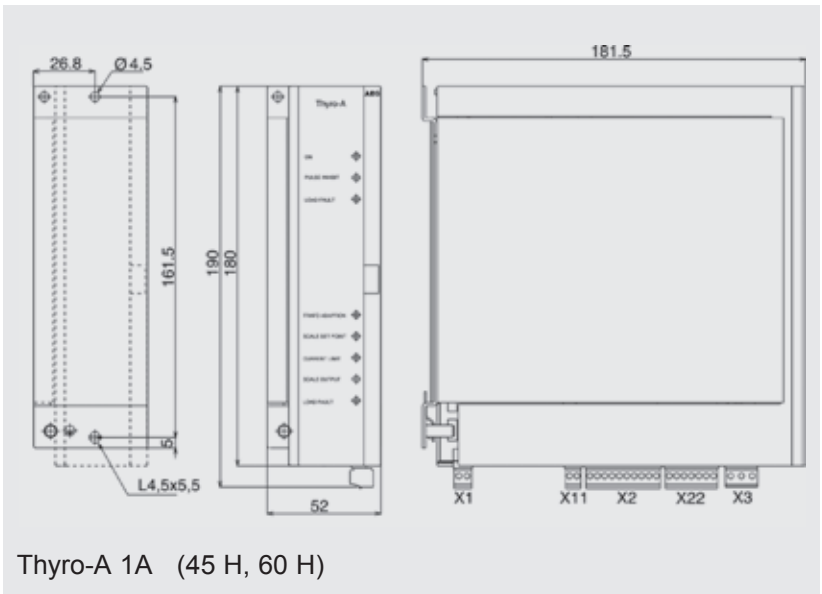
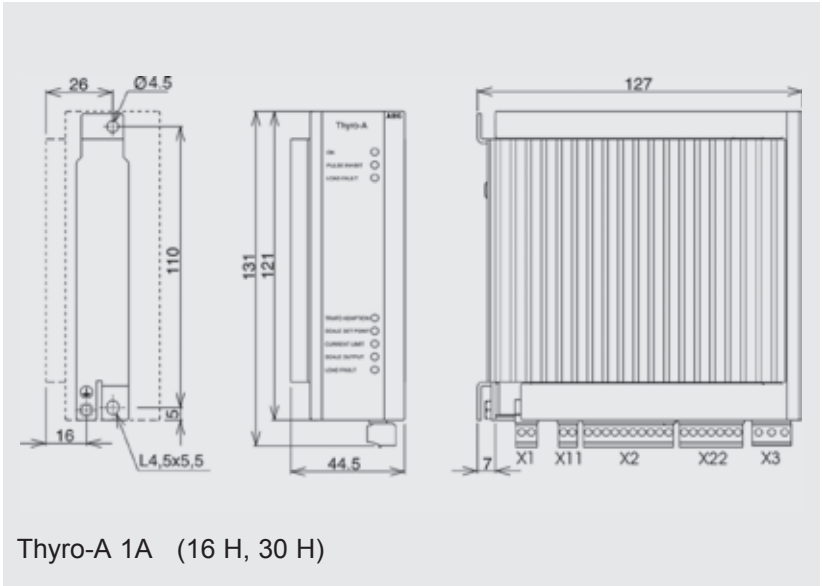

EN

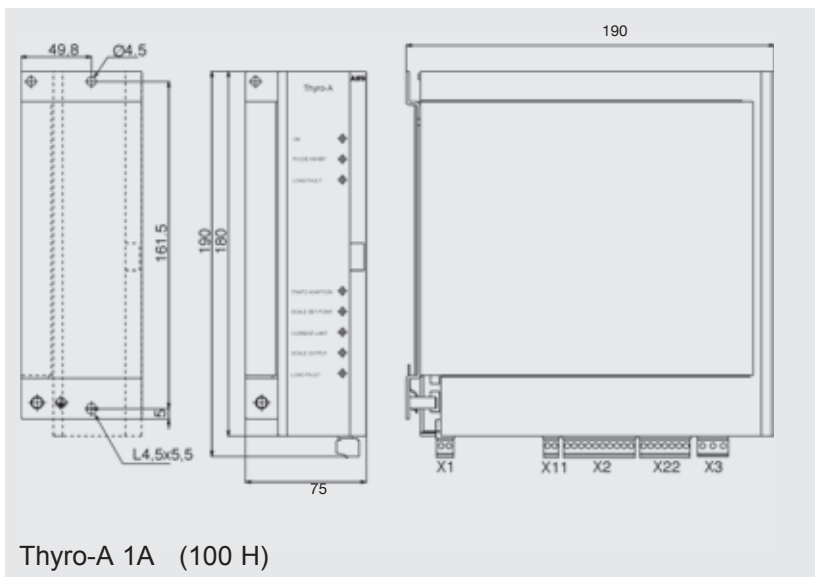

Thyro-A 1A (100 H)

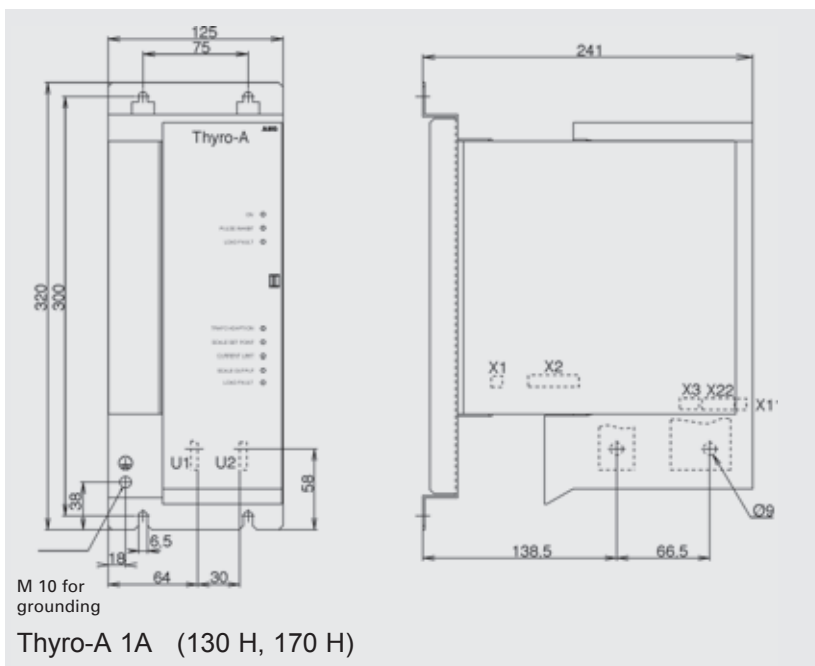

Thyro-A 1A (130 H, 170 H)

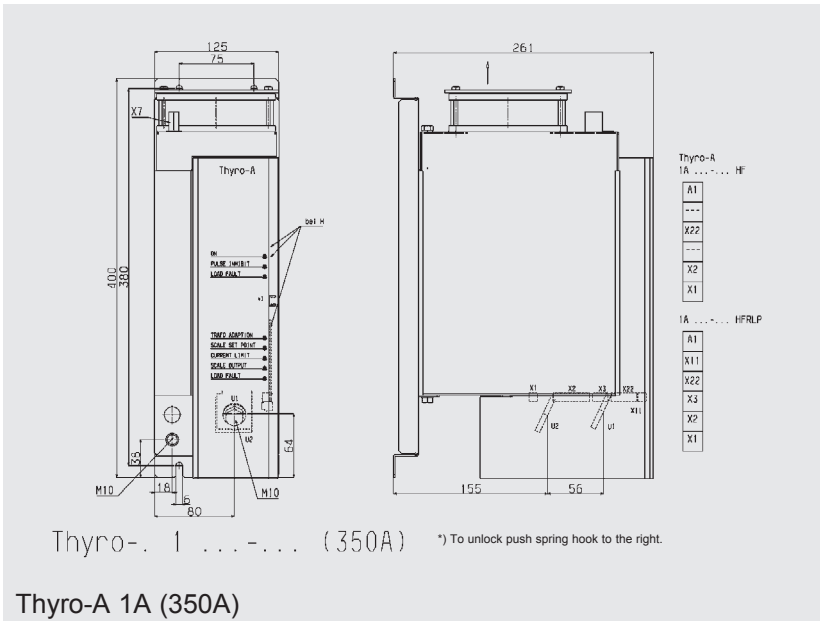
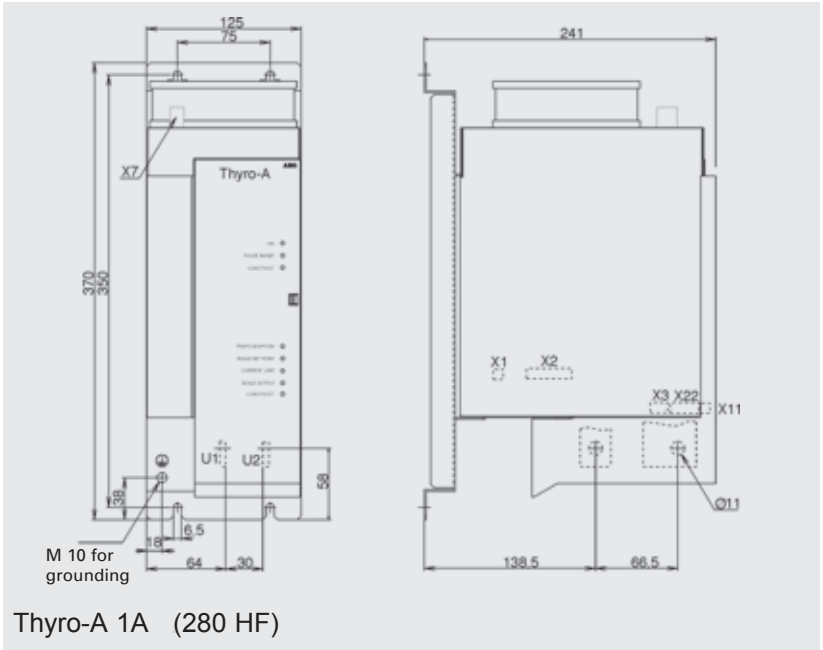

EN

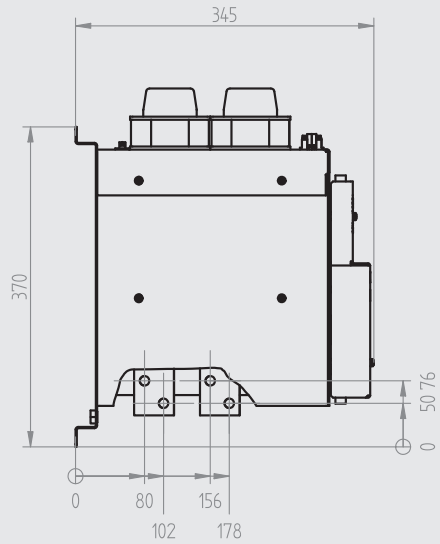
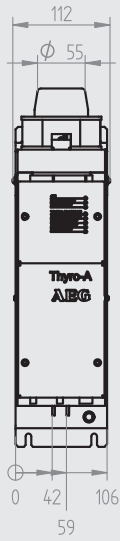

Thyro-A 1A (495A/650A)

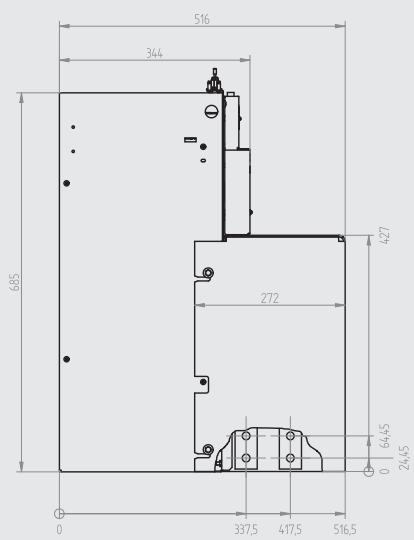
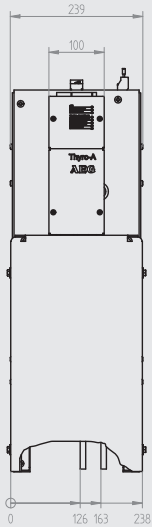

Thyro-A 1A (1000A/1500 A)

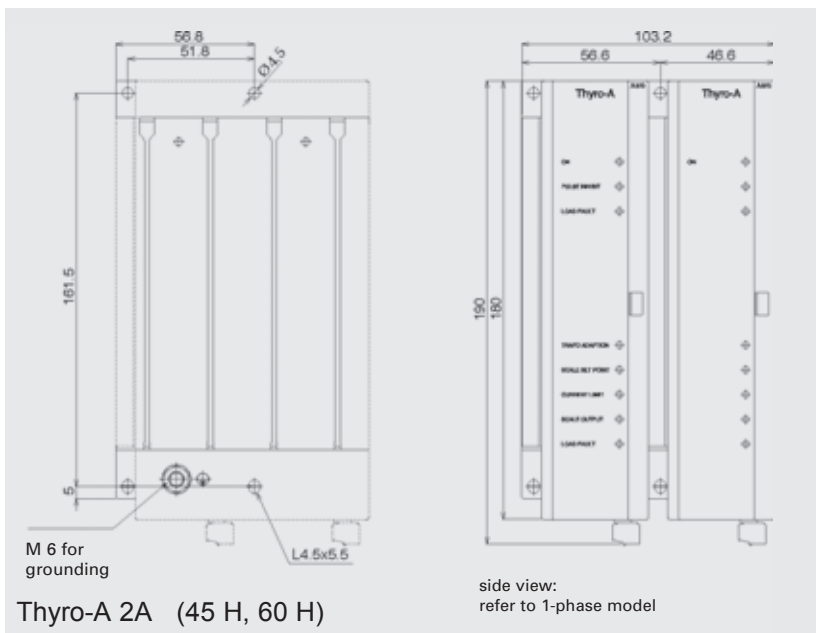
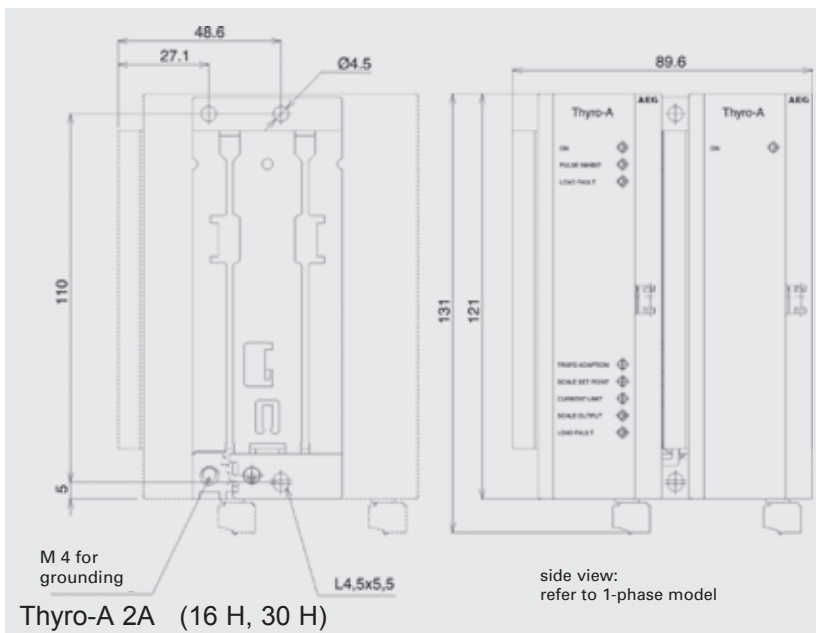

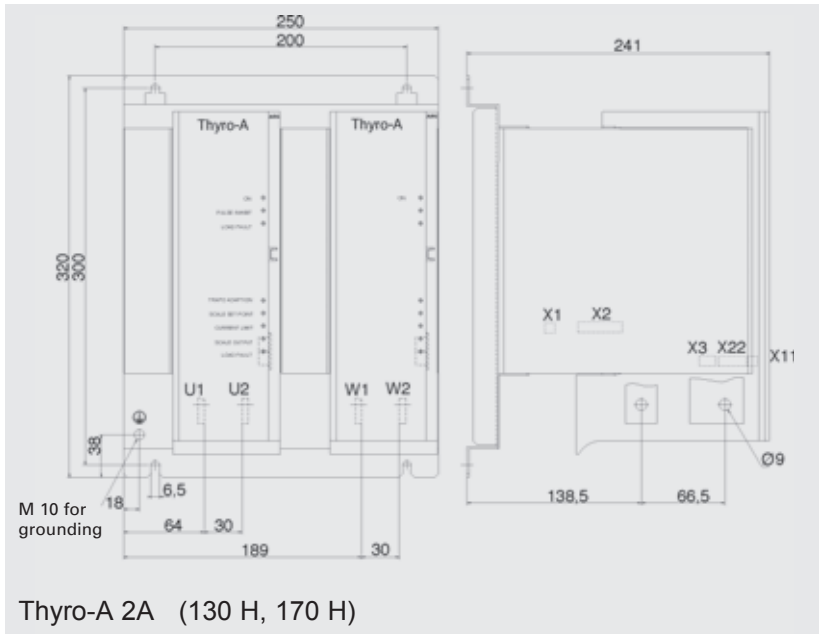
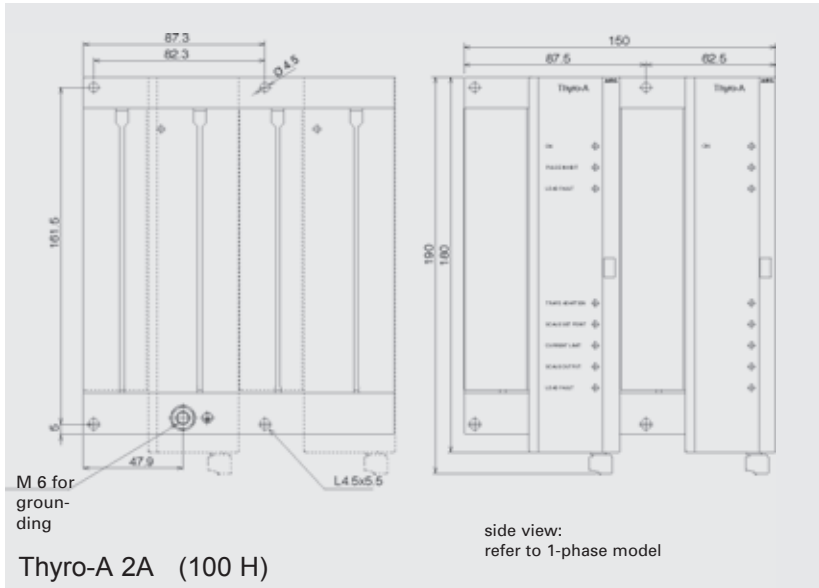

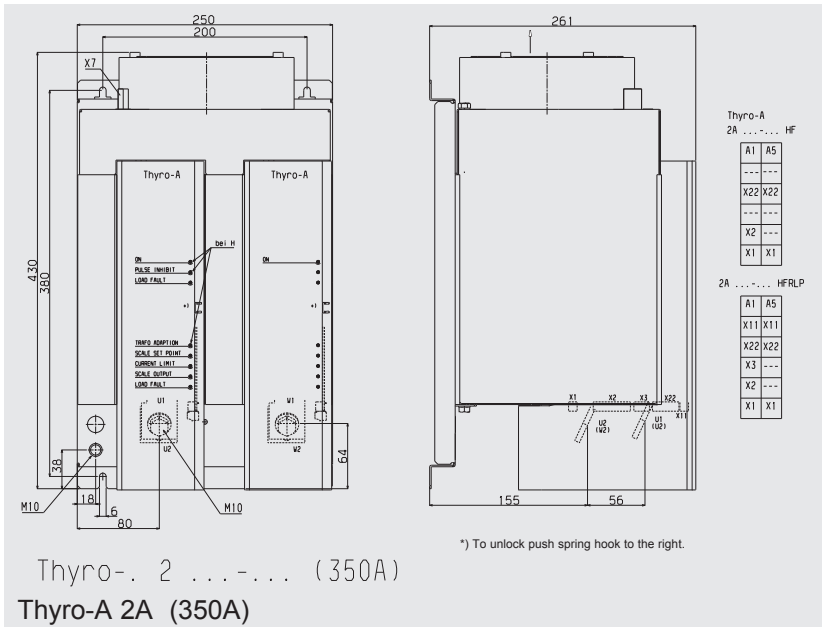
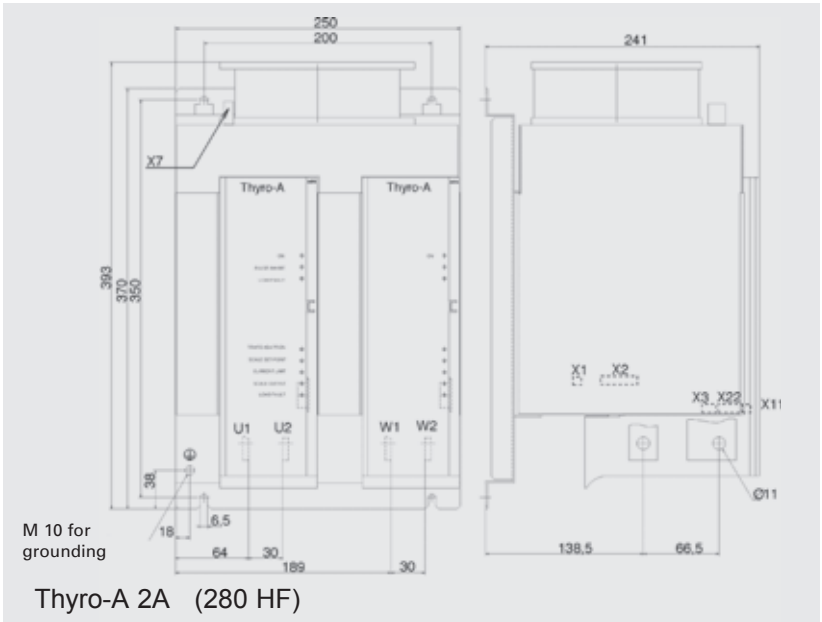

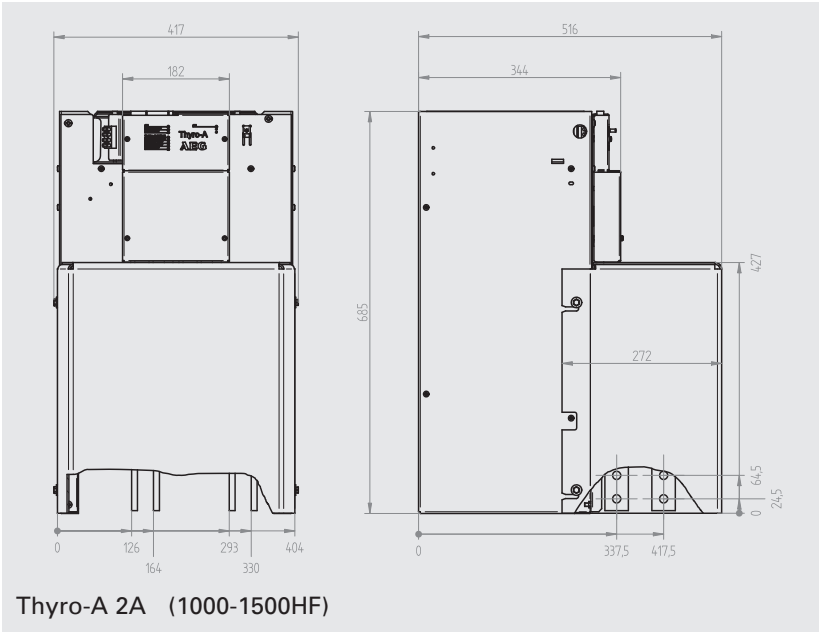
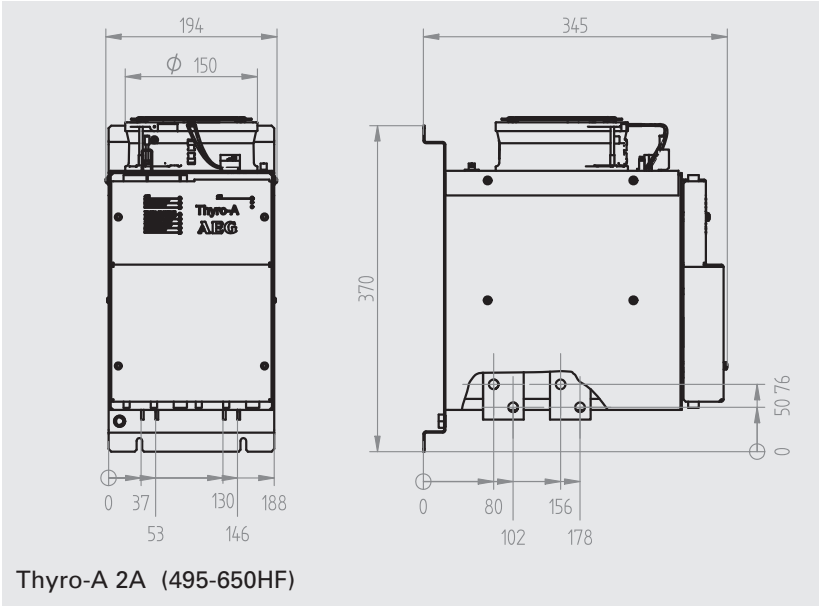

Dimension drawing Thyro-A 3A with 16A / 30A

The dimension drawings are for type ...H RLP1.

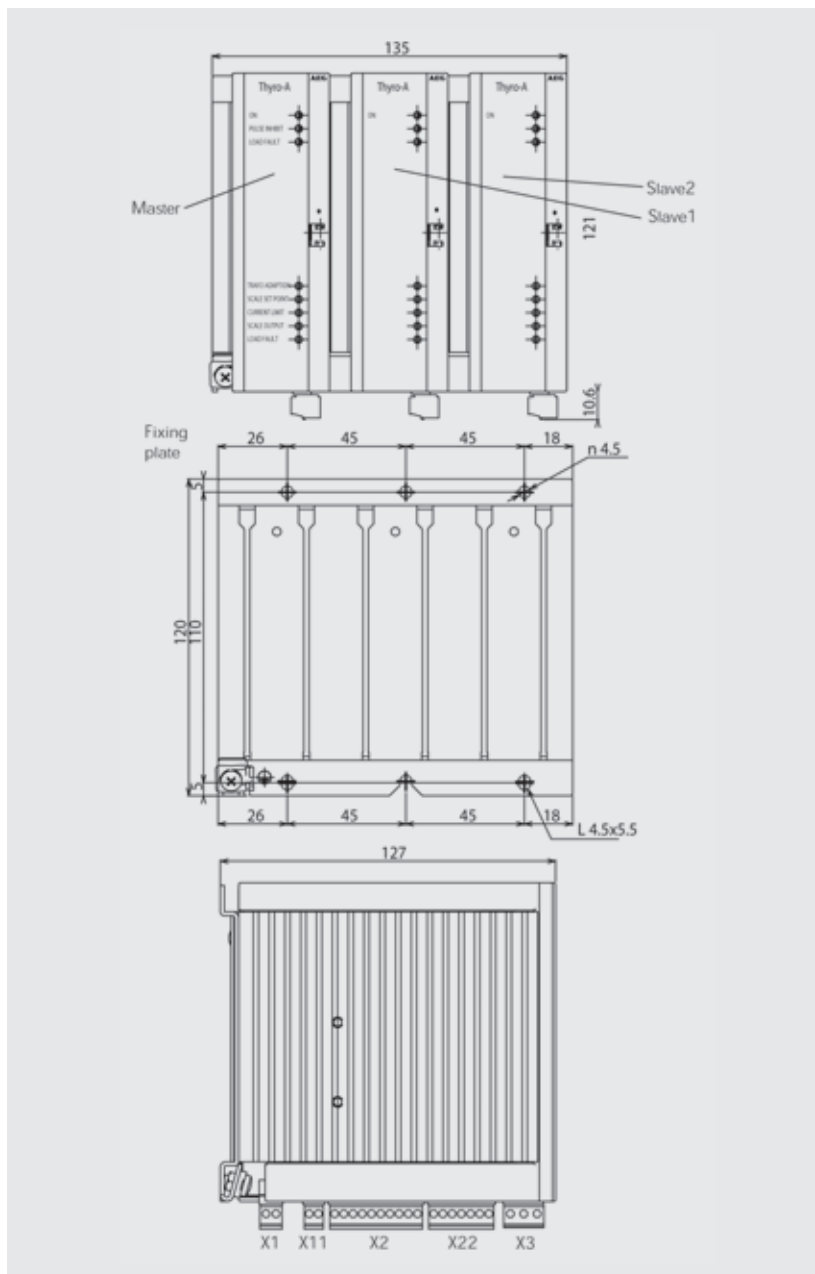

Dimension drawing Thyro-A 3A with 45A / 60A

The dimension drawings are for type ...H RLP1.

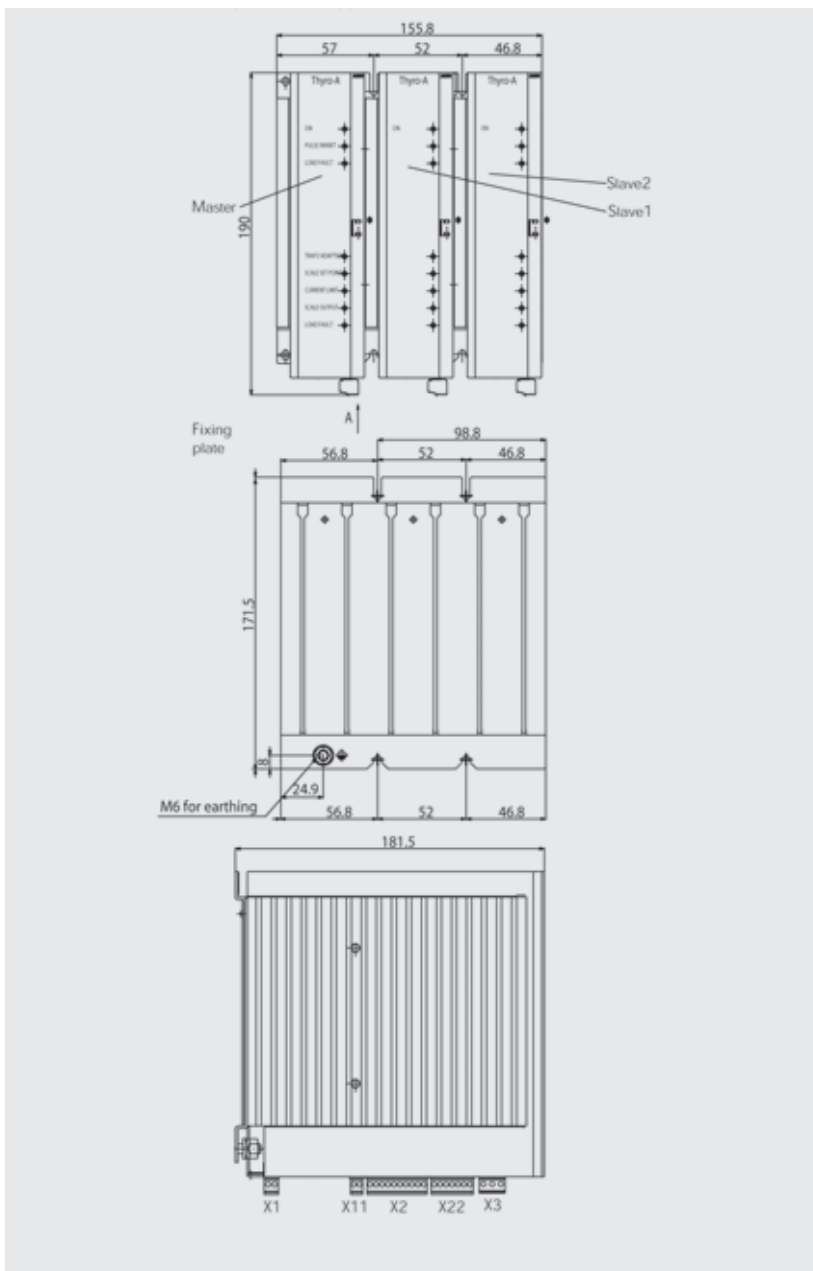

Dimension drawing Thyro-A 3A with 100A

The dimension drawings are for type ...H RLP1.

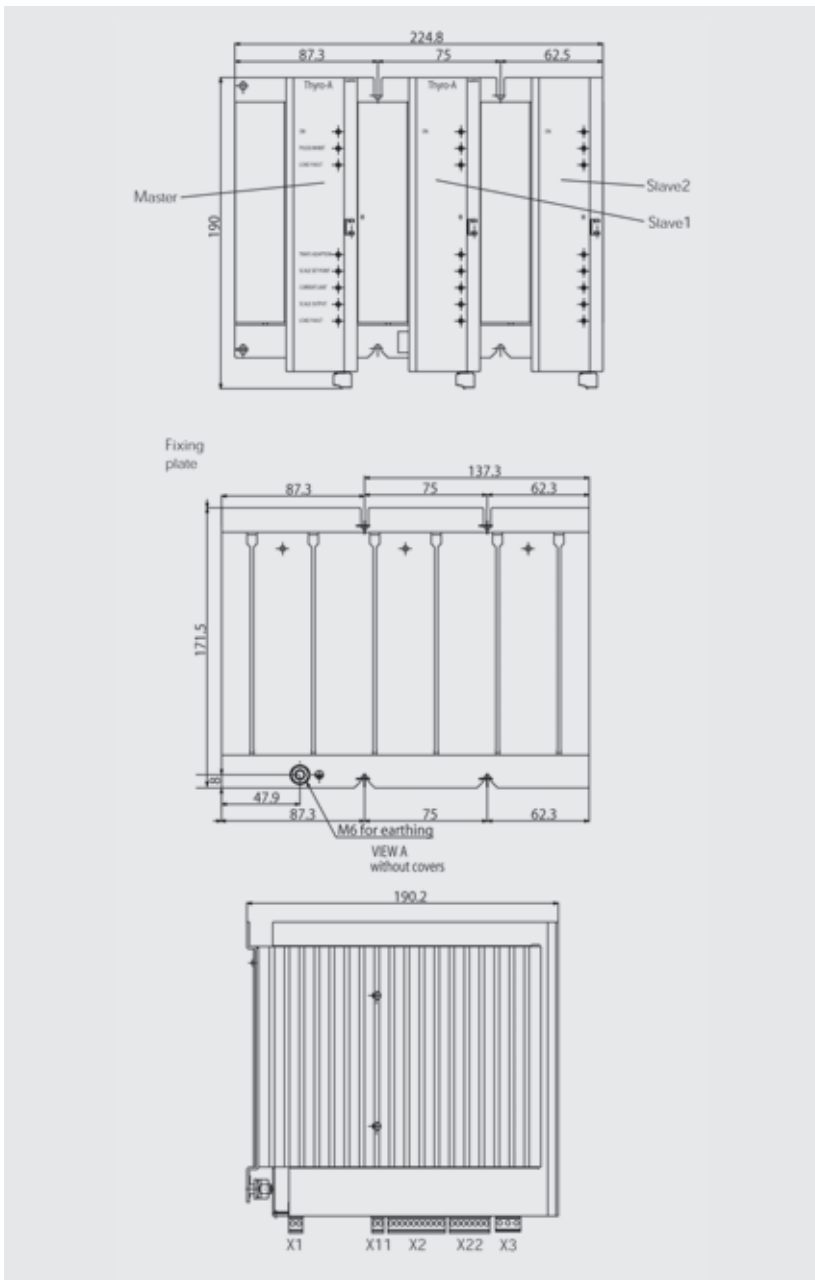

Dimension drawing Thyro-A 3A with 130A / 170A

The dimension drawings are for type ...H RLP1.

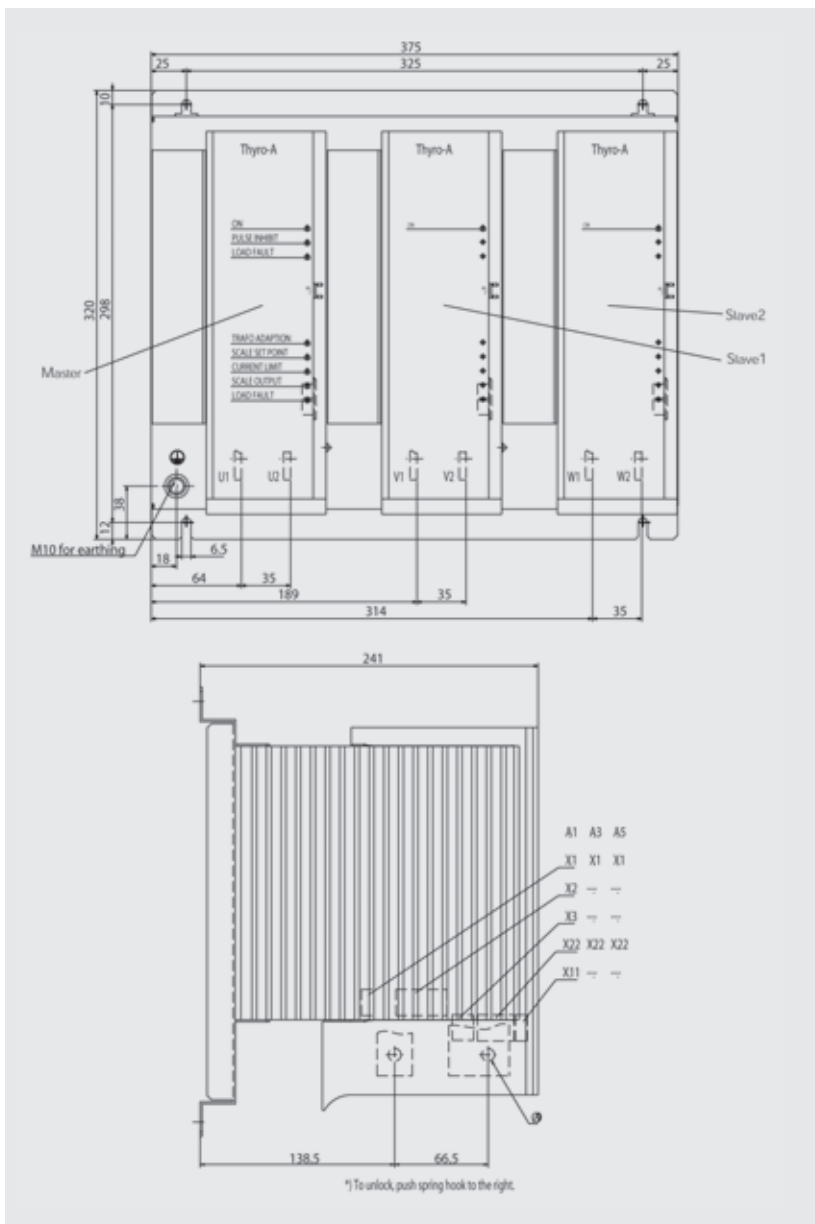

Dimension drawing Thyro-A 3A with 280A

The dimension drawings are for type ...H RLP1.

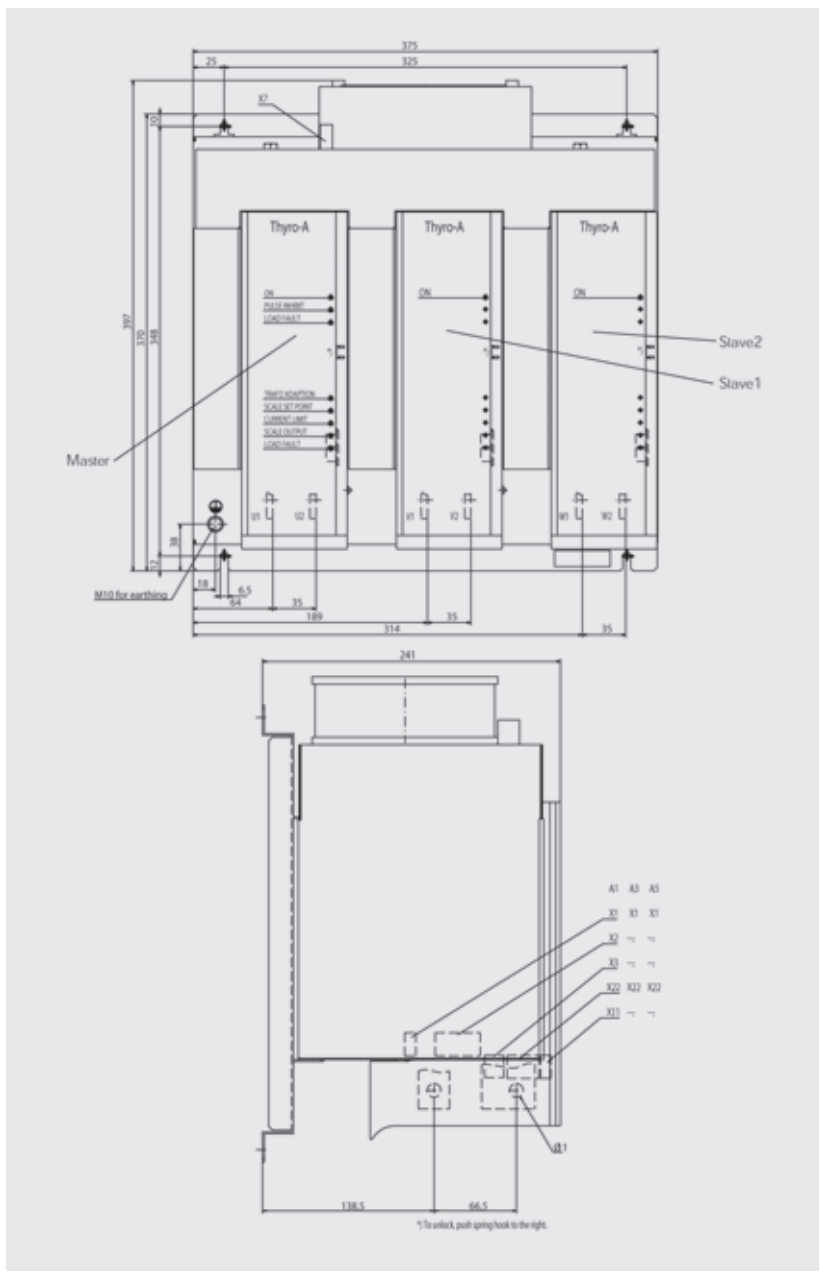

Dimension drawing Thyro-A 3A with 350A

The dimension drawings are for type ...H RLP1.

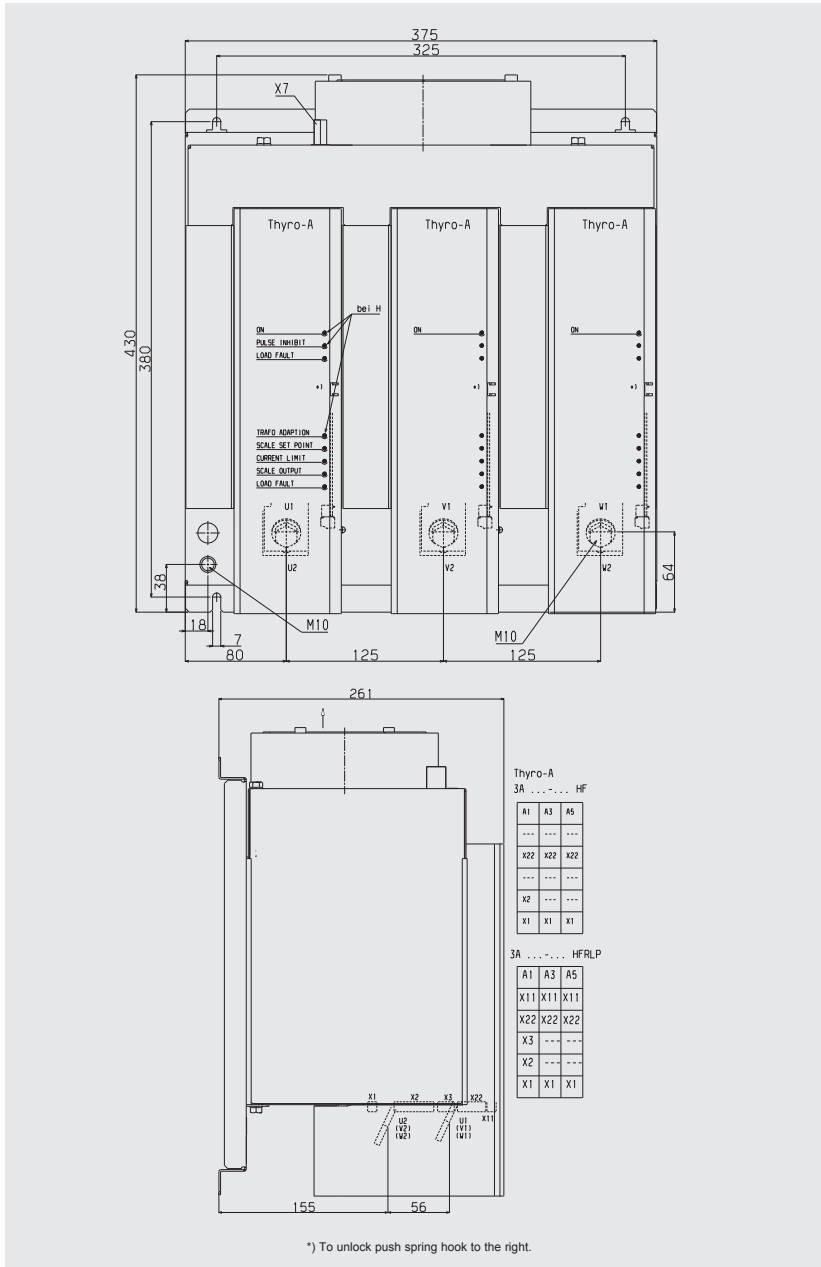

*) To unlock push spring hook to the right.

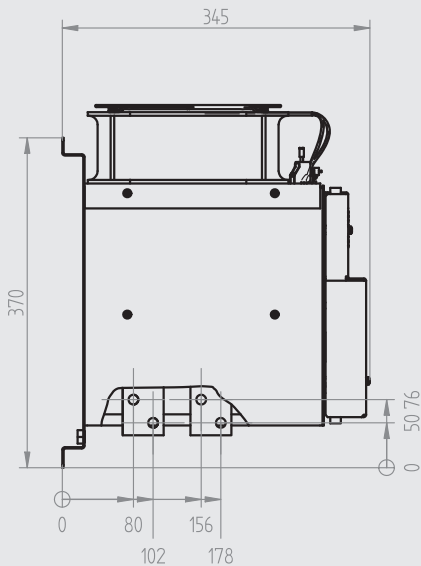
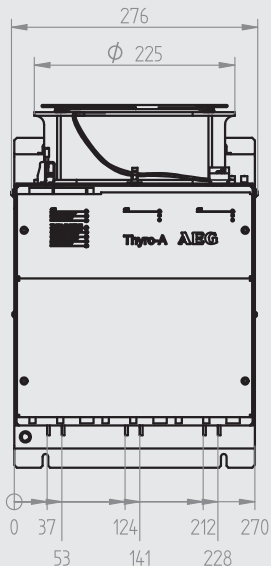

Thyro-A 3A (495-650HF)

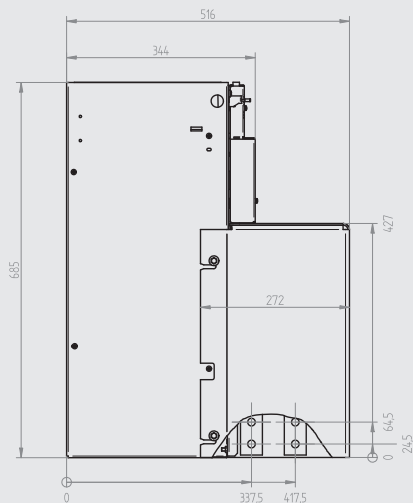
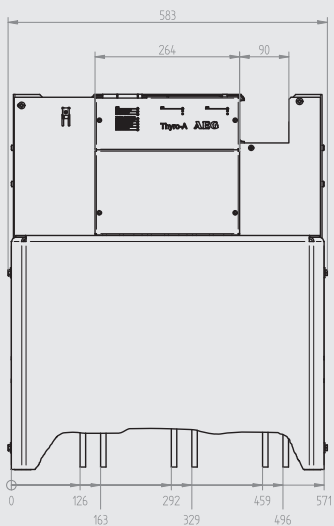

Thyro-A 3A (1000-1500HF)

11. Accessories and options

- Order no. 8.000.006.763 Support for 35 mm snap-on assembly 16A and 35A
- Order no. 8.000.010.791 Support for 35 mm snap-on assembly for 45A and 60A
- Order no. 2000 000 841 Bus module Profibus-DP
- Order no. 2000 000 842 Bus module Modbus RTU
- Order no. 2000 000 843 Bus module CANopen
- Order no. 2000 000 844 Bus module DeviceNet
- Order no. 2000 000 848 Bus module connection cable for 4 controllers, 2.5 m long
- Order no. 2000 000 849 Bus module connection cable for 4 controllers, 1.5 m long
- Order no. 2000 000 380 PC software THYRO-TOOL FAMILY
- Order no. 2000 000 845 PC interface RS232
- Order no. 0048764 Data cable to PC (RS232) 9-pin. SUB-D 5.0 m
- Order no. 8.000.019.086 Adapter cable USB 1.1 to RS232

12. Approvals and conformity

The Thyro-A has the following approvals and conformities:

- Quality standard in acc. with DIN EN ISO 9001
- UL-approval, file No. E 135074, taking into account the Canadian National Standard C 22.2 No. 14-95, certification 16-350A, under preparation 495-1500A. Suitable for use on a circuit capable of delivering not more than 100 kA rms symmetrical Amperes, xxx Volts maximum, when protected by RK5 class fuses
- CE conformity
- Low voltage directive 2006/95/EEC
- EMC directive 2004/108/EEC
- GOST (Russian state standard)
- RoHS compliant 5/6

Directives

The CE mark on the device confirms compliance with the EC directives 2006/95/EG for low voltage and 2004/108/EG for electromagnetic compatibility if the instructions on installation and commissioning described in the operating instructions are followed. There is no product standard for thyristor power controllers, so it is necessary to build up a sensible framework of standards from the corresponding basic standards to guarantee safe application and possibilities for comparison.



CAUTION

If grain oriented, cold rolled sheet metal is used, the induction of the downstream transformer should not exceed 1.45 T for mains overvoltage = 1.2 T nominal induction.

In addition to the standards mentioned, further standards are also complied with, e.g. voltage drops in acc. with 61000-4-11:8.94 are ignored by the control unit or registered by the monitoring being triggered. There is always an automatic start after the mains returns within the tolerances.

In Detail

Device application conditions

Built-in device (VDE0160)		EN 50 178
General requirements		EN 60146-1-1
Design, vertical installation		
Operating conditions		EN 60 146-1-1; ch. 2.5
Area of application, industrial		CISPR 6
Temperature behaviour		EN 60 146-1-1; ch. 2.2
Storage temperature	D	-25°C - +55°C
Transport temperature	E	-25°C - +70°C
Operating temperature better	B	-10°C - +35°C with forced ventilation -10°C - +45°C with natural air cooling -10°C - +55°C with reduced type current -2%/°C Use of the device in UL conditions up to a maximum ambient temperature of 40°C.
Load category	1	EN 60 146-1-1 P.2
Humidity class	B	EN 50 178 Tab. 7 (EN 60 721)
Overvoltage category	III	EN 50 178 Tab. 3 (849V)
Degree of contamination	2	EN 50 178 Tab. 2
Air pressure		900 mbar*; 1000 m above sea level
Degree of protection	IP00	EN 69 529
Protection class	I	EN 50178 chap. 3
Air and creepage distances		housing / mains potential > 5.5 mm housing / control pot. > 1 mm mains volt. / control pot. > 10 mm mains volt. among each other 2.5 mm
Mechanical shocks		EN 50 178 chap. 6.2.1
Test voltage		EN 50 178 tab. 18
Tests in acc. with		EN 60 146-1-1 4.
EMC emitted interference		EN 61000-6-4
Radio interference suppression		
Control unit	Class A	EN 55011; CISPR 11
EMC interference immunity		EN 61000-6-2
Compatibility level	Class 3	EN 61000-2-4
ESD	8 kV (A)	EN 61000-4-2
Electromagnetic fields	10 V/m	EN 61000-4-3

Burst	main lines	2 kV (A)	EN 61000-4-4
	control lines	2 kV (A)	
Surge	main lines	2 kV	
	control lines	asym.	EN 61000-4-5
		1 kV sym.	EN 61000-4-5
		0.5 kV	
Conducted			EN 61000-4-6



AEG

Power Solutions

Emil-Siepmann-Str. 32
59581 Warstein-Belecke
Germany
Tel.: +49(0)2902 763 -520 / -290
Fax: +49(0)2902 763 -1201
www.aegpowercontrollers.com
www.aegps.com

Betriebsanleitung/Operating Instructions 8000029381 DE/ EN 02/11/Version 03

Due to our policy of continuous development, data in this document is subject to change without notice and becomes contractual only after written confirmation.