

## Introduction

The Veeder-Root brand Series 7990 is the best value in a low cost, versatile indicator for industrial applications. Highly flexible, it can be programmed at installation to operate as a totalizer, rate indicator (Model 799008-201 only), or elapsed time meter. With this unique functionality, it can be used to totalize parts production, keep track of machine hours, indicate process times, or show production rate. Input scaling accommodates a variety of signal sources with the ability to readout in meaningful engineering units. Use two or three of them and have matching control panel instrumentation for count, speed, and time. Standardize them throughout your plant, and reduce inventory by stocking just one indicator instead of several.

Many convenience features are included, such as adhesive labels preprinted with popular engineering unit identifiers, security locks for reset and programming, and accessory snap-on adaptor modules. The adaptor modules allow screw-terminal wire connection and/or accommodation of high-voltage input signals for timing or counting applications. Accessory panel adapters, available with or without a locking key reset, allow easy mounting and retrofit to older and larger mechanical, electrical or electronic products.



### Features

- Large, easy to read 8-digit LCD (5-digit, rate mode)
- Heavy, diecast enclosure for industrial duty application
- Simple programming procedure selects operating mode and other functions
- Tamper proof programming mode lock
- Operates without external power – long life lithium battery
- Totalizer mode has input scaling and selectable decimal point
- Rate mode utilizes a time interval method for improved accuracy.
- Timer modes for hours, minutes, seconds with choice of time increment
- Front panel reset, remote reset, or nonreset operation

### Index

Overview	
Construction	page 2
Rear Panel Features	page 2
Specifications	page 3
Panel Mounting	page 3
Setup	
Wiring	page 4
Front Panel Operation	page 4
Count Mode	page 5-6
Hour Meter Mode	page 6
Timer Mode	page 6
Rate Meter Mode	page 6-7
Option Modules	page 7-8
General	
Warranty	page 8

**Technical Manual**  
**701930-0000**

**Veeder-Root brand**  
**7990**  
**Totalizer/**  
**Hourmeter/**  
**Timer/**  
**Ratometer**

# O V E R V I E W

## CONSTRUCTION

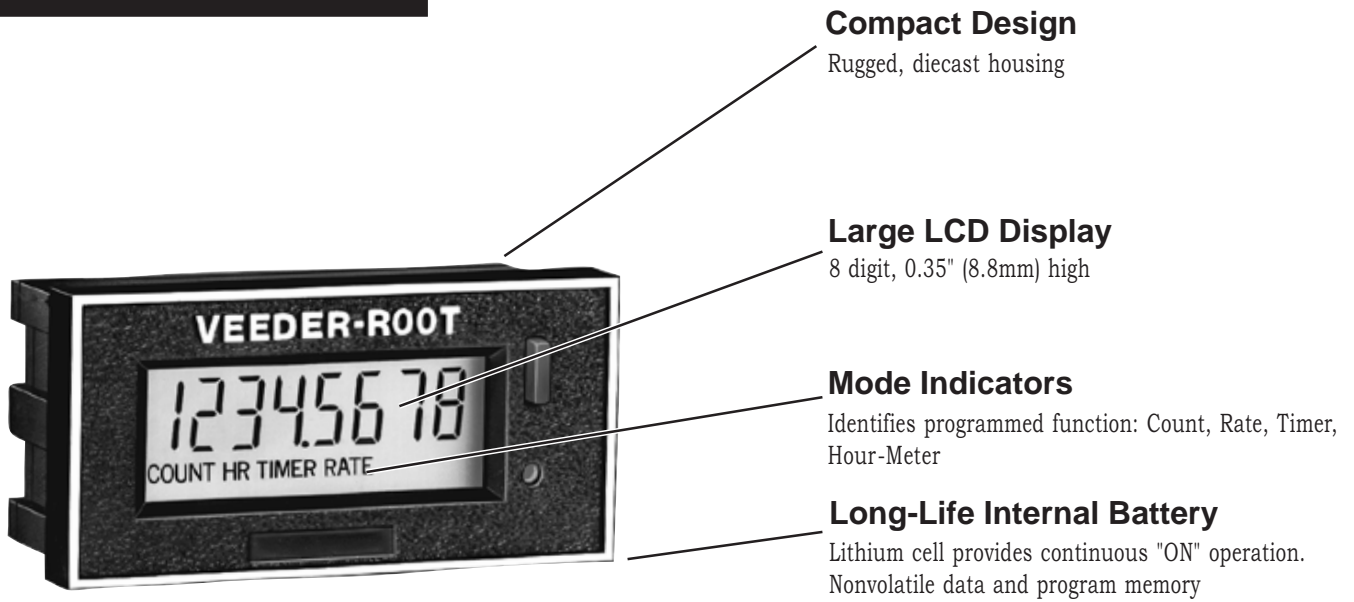

## Rear Panel Features

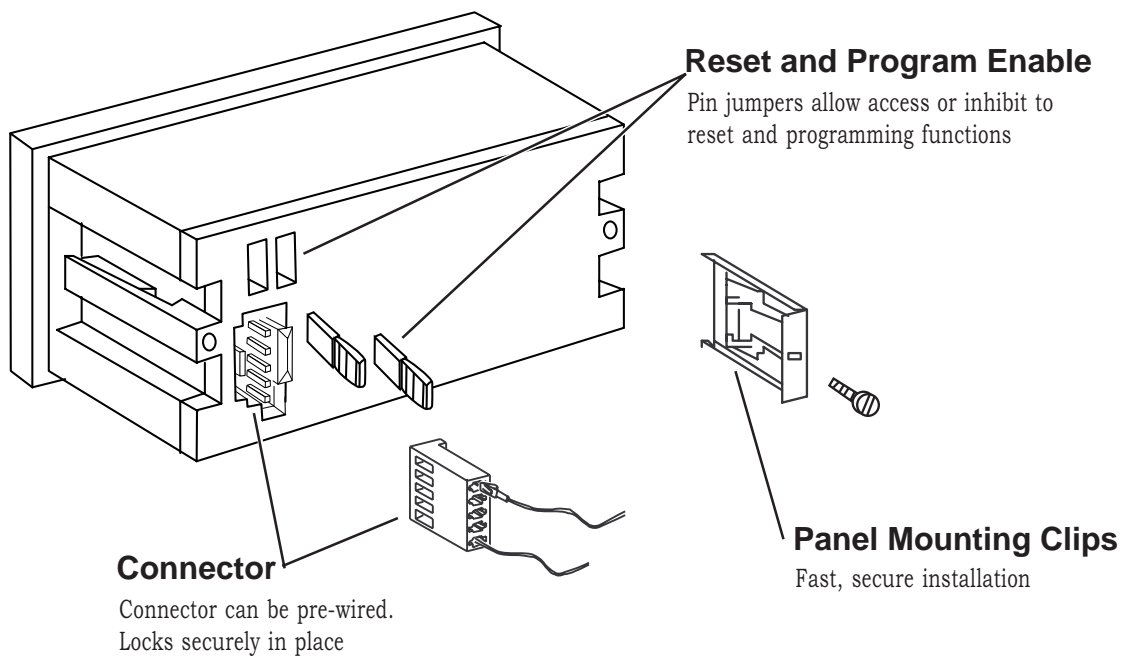

## SPECIFICATIONS

### General

Power Source: Internal Lithium Battery  
 Battery Life: Eight year typical life  
 Temperature Range: 0° to +75 C°(+32° to +167° F)

### Inputs

High Speed  
 Count Speed: 10 KHz, 50µs min. high/low pulse; for use with TTL, CMOS, Open Collector, NPN transistor or magnetic sensor  
 Sensitivity: Low Level Logic < 1.0 VDC  
 High Level Logic > 2.0 VDC  
 Maximum Voltage: 28 VDC

### Low Speed

Count Speed: 40 Hz, 12ms min. pulse; for use with isolated switch/relay contact  
 Sensitivity: Low Level Logic < 1.0 VDC  
 High Level Logic > 2.0 VDC  
 Maximum Voltage: 28 VDC

### Reset

Types: Front panel button and remote input through contact closure between rear terminal pins 4 and 5. (Applies only when configured for Count or Elapsed Time modes)  
 Min. Pulse Width: 0.5ms

### Functions

Totalizer: Eight digit capacity, programmable prescaler (divide by 1 to 9999), X1 or X2 (count both leading and trailing edge) logic; Front panel or remote reset

Elapsed Time Indicator: Eight digit capacity; registers elapsed time when signal input is held ON; Programmable resolution of hours, tenths of hours, hundredths of hours, minutes, tenths of minutes or seconds; front panel or remote reset

Hour Meter: Eight digit capacity; registers hours in whole units, tenths, or hundredths, non-resettable

\*Rate Meter: Four digit capacity; time interval method with prescaler (multiply by .0001 to 9999) converts pulses to rate

### Mechanical

Dimensions: 35.6 mm x 71.9 mm, x 33.3 mm deep  
 Panel Cutout Size: 66.8 mm x 33.2 mm  
 Panel Thickness: 2mm to 13mm  
 Depth Behind Panel: 20.7 mm

### Display

Type: Liquid Crystal Display  
 Height: 0.35" (9mm)  
 Number: 8 digits (4 digit in Rate Meter mode)  
 Decimal Point: Programmable from 0 to 4 places (0 to 3 places for Rate)

\*Rate mode, model 799008-201 only

## PANEL MOUNTING

Install unit in panel cutout using gasket and hardware provided per the drawing below.

**Note: Do not overtighten screws. Tighten only until gasket begins to compress.**

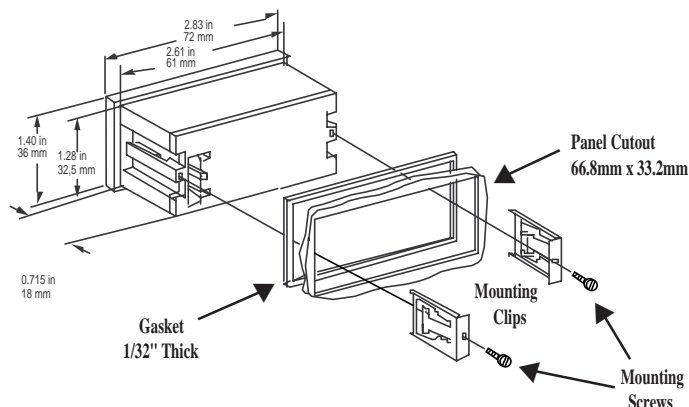

# SETUP

## WIRING

The FLEX uses a detachable terminal strip to make wiring more convenient. Included are the terminal strip and 4 colored wires with locking tangs attached. The black common wire is installed in the terminal strip at the factory, and should always be used in that position. Wires can be removed from the terminal strip by inserting a small screw driver into the slot on the side of the strip and gently pressing on the locking tang while pulling gently on the wire.

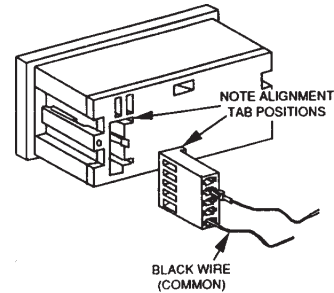
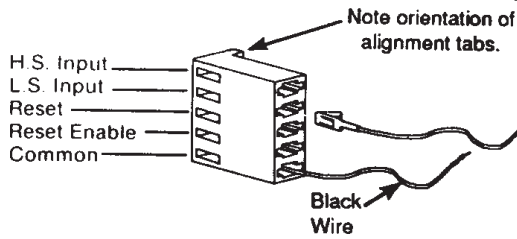

**Note:** Do not install wires for functions that are not used.

## OPERATION

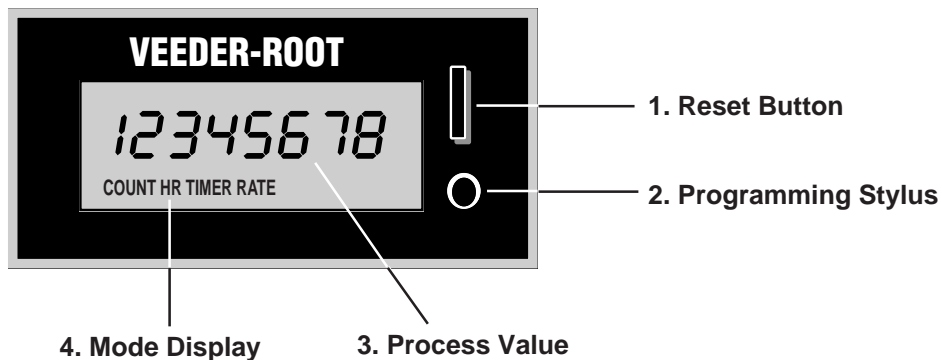

**1. Reset Switch:** Used to reset the present value in Count or Timer mode. The Reset function will only be activated if the Reset Enable jumper is set to the ON position, or if the rear terminal Reset Enable input (pins 4 and 5) is connected. In Set-up mode, this button is used to set parameter values by incrementing the highlighted number or scrolling through the possible choices.

**2. Programming Stylus:** Used in Set-up mode to advance from one parameter to the next and to move between digits in a numerical value.

**3. Present Value:** Displays the current Count, \*Rate or Time value in operating mode. In Set-up mode displays the parameter value.

**4. Operating Mode Display:** Based on how the unit is programmed, one of the 4 above displays will be illuminated to indicate the chosen mode of operation. A flashing display indicates that the controller is in Set-up mode.

\*Rate mode, model  
799008-201 only

## SET-UP OVERVIEW

Located on the back of the unit are two jumpers which are used to enable operation of the front panel reset button and programming stylus. Before beginning the set-up procedure it is necessary to set these two jumpers to the ON position. After set-up is complete, the jumpers may be moved to the OFF position to prevent unauthorized changes or accidental reset of the count or elapsed time value.

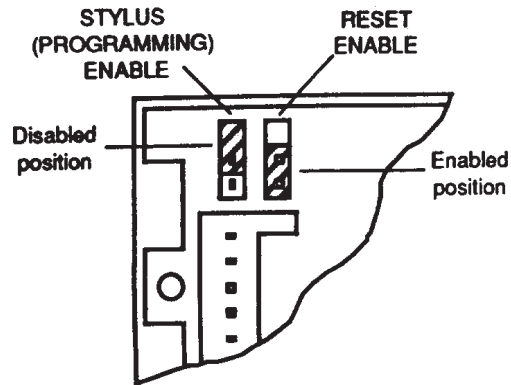

COUNT HR TIMER RATE

### Operating Mode Selection

Depressing the recessed stylus will activate the Operation Mode selection menu. All four mode indicators will be illuminated with the presently chosen one flashing. Use the Reset key to scroll between the modes. Once the desired mode is flashing, it can be entered for set-up by depressing the stylus key.

## COUNT MODE

In Count Mode, the unit operates as an eight digit decimal totalizer. Leading zeroes are suppressed. The reset button, if enabled, and the remote reset input can reset the count to zero at any time. Counting will not resume until the reset is released.

COUNT 0001

### Prescale Value

The four digits on the right-hand side of the display represents the value by which the input signal will be divided before a pulse is sent to the display counter. For example if 20 pulses represented one display unit, a value of 20 would be entered for this parameter. The value can be set by depressing the reset key to increment the currently flashing number, starting with the right most digit. The stylus key is used to scroll to the next digit to the right on the display. Default value is 0001.

**Note: A prescale value of 0000 is not valid. If no prescaling is required, leave this parameter at the default value of 0001.**

1 COUNT 0001

### Count Logic

Depress the stylus key until the digit on the far left of the display begins to flash. This digit selects the count logic, which indicates whether counting is done on only the falling edge (1) of the input or both the rising and falling edge of the input (2). Use the reset key to toggle between the two values. Default is 1.

# SETUP



## Decimal Point Position

After the count logic has been set, depressing the stylus key will bring up the decimal point position display. The position can be changed by depressing the reset key. Each successive press of the key will move the decimal position one place to left, up to a maximum of four places. Default is zero places.

After the decimal position has been set, depressing the stylus will cause the unit to return to Operating mode.

**Note: In count mode this parameter serves as a cosmetic decimal point that will not effect the calibrated resolution. For example, if the display showed 123 with the Decimal Point Position set to 0, changing the position to 1 will cause the display to show 12.3.**

## HOUR METER MODE

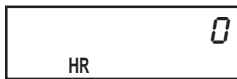

## Display Resolution

The accumulated time can be displayed in whole hours, tenths of hours or hundredths of an hour. Depressing the reset switch will scroll the display between these three choices. Default is whole hours.

After the display resolution has been set, depressing the stylus key will cause the unit to return to Operating mode.

In Hour Meter mode, the unit accumulates time whenever the input is held active. Front panel and Remote Reset functions are inoperative. The Present Value can only be reset by entering Set-up mode.

## TIMER MODE



## Display Resolution

The accumulated time can be displayed in one of the following resolutions: seconds, minutes, tenths of minutes, hours, tenths of an hour, hundredths of an hour. Depressing the reset key will scroll the display between these six choices. Default is seconds.

After the display resolution has been set, depressing the stylus key will cause the unit to return to Operating mode.

In Timer mode, the unit accumulates time whenever the input is held active. The reset button, if enabled, and remote reset can be used to reset the timer at any time.

## RATE MODE

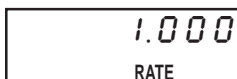

## Prescale Value

The four digits on the right hand side of the display represents the value by which the input signal will be multiplied before a pulse is sent to the display counter. This value can be set in a range from 0.001 to 9.999. Depressing the reset key will move the decimal position to the right. After the position has been set, depressing the stylus key will enable the value to be set. Use the reset key to increment the currently flashing number starting with the right-most digit. The stylus key is used to scroll to the next digit to the right on the display. Default value is 1.000

**Note: A prescale value of 0000 is not valid. If no prescaling is required, leave this parameter at the default value of 1.000.**

In Rate Mode (Rate mode, model 799008-201 only), the unit displays events per time. It can be use as a tachometer or to display other rates; production, flow, etc.

### Rate Prescale Example:

This unit determines rate based on input frequency, thus if the Prescale Value is left at 1.000, the value displayed would be number of pulses per seconds. Based on this, the basic formula for the Prescale Value is:

$$\frac{1}{\text{Pulses per Display Unit}} \times \frac{\# \text{ of seconds}}{1} = \text{Prescale Value}$$

Revolutions per minute (RPM) can be displayed using a 360 PPR encoder as the input by setting the Prescale Value according to the formula below:

$$\frac{1}{360} \times \frac{60}{1} = .167$$

Gallons per hour can be displayed using a 20 pulse per gallon flow meter as the input by setting the Prescale Value according to the formula below:

$$\frac{1}{20} \times \frac{3600}{1} = 180.0$$



### Decimal Point Position

After the left-most digit on the Prescale Value has been set, depressing the stylus will bring up the Decimal Point Position Display. This parameter applies to the rate display and is not related to the decimal point position for the Prescaler. The position can be changed by depressing the reset key. Each successive press will move the decimal position one place to the left up to a maximum of three places. Default is zero places.

**Note: In Rate mode, this parameter serves as a function decimal point that will effect the displayed resolution. For example, if the displayed value was 123 with the Decimal Point Position set at 0, changing the decimal point position to 1 would cause the display to read 123.X, with X representing tenth of a unit resolution.**

## OPTION MODULES

Three option modules are available to snap-mount to the rear of the 7990: a screw terminal adaptor; an AC/DC input module and a Triac Input module.

### Option Module Installation

1. Remove the two jumpers from the back of the instrument that enable the reset and stylus keys. Place these jumpers in their corresponding positions on the back of the option module.
2. Place the six-position pin extender into the connector on the bottom of the option module.
3. Position the option module so that the pin extender lines up with the connector on the back of the instrument. Press together until the option module snaps into position flush to the back of the instrument.

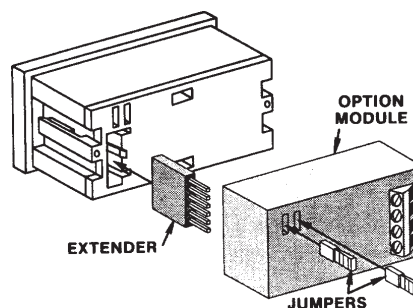

## Option Module Wiring and Installation

The Screw Terminal Adaptor (Part # 328992-010) provides the convenience of screw terminal connection of input signal and remote reset. Wire signal and reset input according to the wire diagram on page 4.

The AC/DC Input Module (Part # 328992-020) allows use of a high-voltage input signal of 24 to 270 volts AC or DC. Impulse frequency response is 0 to 10 Hz. It is optically isolated for maximum immunity to electrical transients and interference. Refer to the diagram below for wiring information.

The Triac Input Module (Part # 328992-030) allows use of a 115 VAC, 50/60 Hz switching devices as input signal source. Impulse frequency response is 0 to 10 Hz. The module is optically isolated. Refer to the diagram below for wiring information.

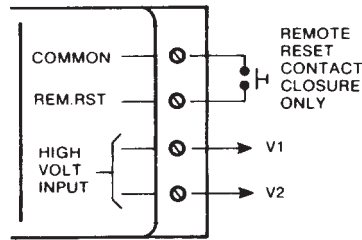

## WARRANTY

Standard products manufactured by the Company are warranted to be free from defects in workmanship and material for a period of one year from the date of shipment, and products which are defective in workmanship or material will be repaired or replaced, at the option of the Company, at no charge to the Buyer. Final determination as to whether a product is actually defective rests with the Company. The obligation of the Company hereunder shall be limited solely to repair and replacement of products that fall within the foregoing limitations, and shall be conditioned upon receipt by the Company of written notice of any alleged defects or deficiency promptly after discovery within the warranty period, and in the case of components or units purchased by the Company, the obligation of the Company shall not exceed the settlement that the Company is able to obtain from the supplier thereof. No products shall be returned to the Company

without its prior consent. Products which the Company consents to have returned shall be shipped F.O.B. the Company's factory. The Company cannot assume responsibility or accept invoices for unauthorized repairs to its components, even though defective. The life of the products of the Company depends, to a large extent, upon the type of usage thereof, and THE COMPANY MAKES NO WARRANTY AS TO FITNESS OF ITS PRODUCTS FOR SPECIFIC APPLICATIONS BY THE BUYER NOR AS TO PERIOD OF SERVICE UNLESS THE COMPANY SPECIFICALLY AGREES OTHERWISE IN WRITING AFTER THE PROPOSED USAGE HAS BEEN MADE KNOWN TO IT.

THE FOREGOING WARRANTY IS EXCLUSIVE AND IN LIEU OF ALL OTHER WARRANTIES EXPRESSED OR IMPLIED, INCLUDING, BUT NOT LIMITED TO ANY WARRANTY OF MERCHANTABILITY OR OF FITNESS FOR A PARTICULAR PURPOSE.

